

LSM-B-SA1

● 10 to 500 N

3-component Force Transducer

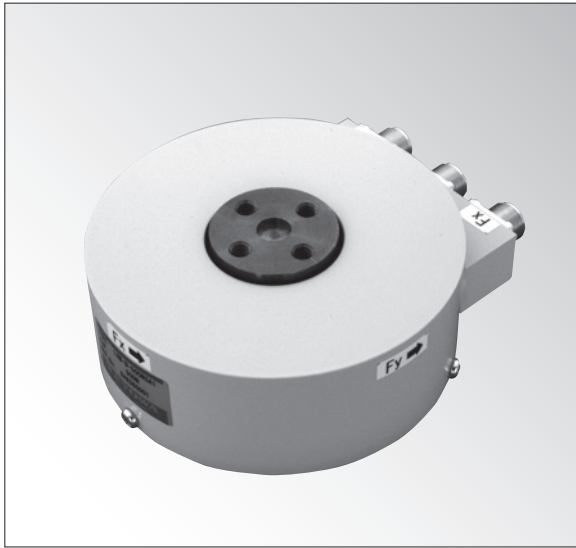

Suitable for special purposes and model experiments.
Compact & lightweight
Easy to handle
Measures 3-component force (X, Y, Z) simultaneously.

■ Dimensions

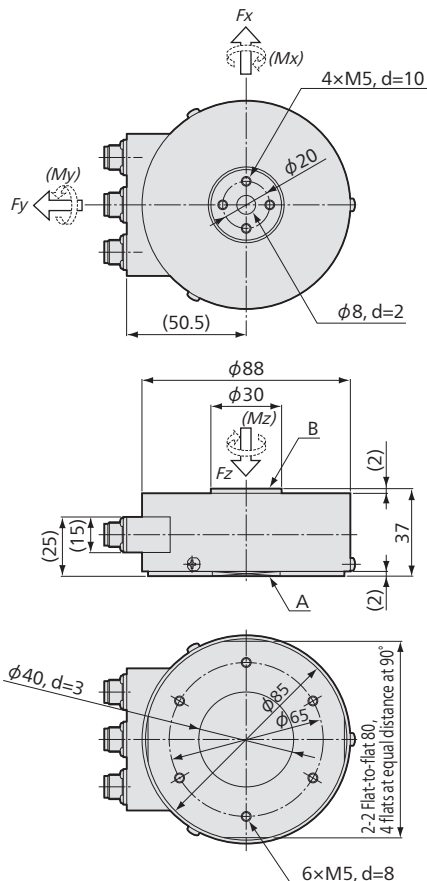

Specifications

Performance

Rated Capacity	See table below.
Nonlinearity	Within $\pm 0.5\%$ RO
Hysteresis	Within $\pm 0.5\%$ RO
Interference	Within $\pm 3\%$ RO
Rated Output	Approx. 0.5 mV/V

Environmental Characteristics

Safe Temperature	0 to 80°C
Compensated Temperature	0 to 70°C
Temperature Effect on Zero	Within $\pm 0.05\%$ RO/°C
Temperature Effect on Output	Within $\pm 0.05\%$ /°C

Electrical Characteristics

Safe Excitation	10 V AC or DC
Recommended Excitation	1 to 5 V AC or DC
Input Resistance	240 Ω $\pm 5\%$
Output Resistance	240 Ω $\pm 5\%$
Cable	4-conductor (0.08 mm ²) chloroprene shielded cable, 4 mm diameter by 5 m long
	Sensor side: R03-PB5M
	Measuring instrument side: Bared at the tip
	(Shield wire is not connected to the case.)

Mechanical Properties

Safe Overloads	150%
Natural Frequencies	See table below.
Weight	See table below.
Safe Moments	See table below.

To Ensure Safe Usage

LSM-B-SA1 series does not feature waterproof structure.

(Note 1) No moments of M_x , M_y , and M_z are measured.
(Note 2) Arrows indicate directions of component force in plus polarity acting to the B plane with the A plane fixed.

Models	Rated Capacity F_x, F_y, F_z	Natural Frequencies (Approx.)			Safe Moment (Approx.) M_x, M_y, M_z	Weight (Approx.)*
		X	Y	Z		
LSM-B-10NSA1	± 10 N	0.3 kHz	0.2 kHz	1.2 N·m	600 g	
LSM-B-20NSA1	± 20 N	0.4 kHz	0.3 kHz	2.4 N·m		
LSM-B-50NSA1	± 50 N	0.8 kHz	0.6 kHz	5.9 N·m		
LSM-B-100NSA1	± 100 N	1.3 kHz	0.9 kHz	9.8 N·m		
LSM-B-200NSA1	± 200 N	2.5 kHz	2.0 kHz	24 N·m	1.6 kg	
LSM-B-500NSA1	± 500 N	2.2 kHz	1.8 kHz	59 N·m		

Safe moments are stated for reference to strength. *Excluding cable

Bared at the tip

