

Switch Amplifier KHA6-SH-Ex1

- 1-channel isolated barrier
- 115/230 V AC supply
- Input for approved dry contacts or SN/S1N sensors
- Relay contact output
- Fault indication output
- Line fault detection (LFD)
- Up to SIL 3 acc. to IEC/EN 61508
- Up to PL d acc. to EN/ISO 13849

CE  **SIL3 PL d**

Function

This isolated barrier is used for intrinsic safety applications. The device transfers digital signals (SN/S1N proximity sensors or approved dry contacts) from a hazardous area to a safe area. The input controls 1 relay contact output with 3 NO contacts (1 output is in series to the both output relays for the safety function), 1 relay contact output with 1 NO contact, and 1 passive transistor output (fault indication output). Unlike an SN/S1N series proximity sensor, a mechanical contact requires a 10 kΩ resistor to be placed across the contact in addition to a 1.5 kΩ resistor in series. Lead breakage (LB) and short circuit (SC) conditions of the control circuit are continuously monitored. During a fault condition, the fault indication output energizes and outputs I and II de-energize. For safety applications up to SIL 3, output I must be used. For safety applications up to SIL 2, output I and output II can be used.

Application

The input (terminals 10, 12) may generally be operated only with **potentially** free (passive) switches. Single channel operations up to SIL 3 **must** occur via terminals 13 and 14. The center tap of the contacts (terminals 19, 20) can **also** be used if an operation is to occur a redundant branch. If the device is used for safety operations the information in the test documents should be observed. The **fault message** output III delivers an 1-signal when the control circuit experiences lead breakage (LB) or a short circuit (LK). The device (housing type E) has integrated terminals.

Connection

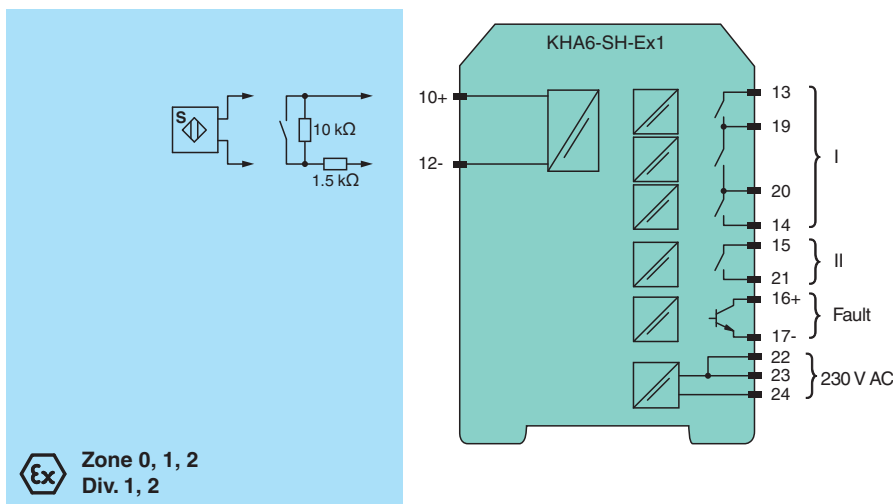

Technical Data

General specifications

Signal type Digital Input

Functional safety related parameters

Release date: 2025-02-04 Date of issue: 2025-02-04 Filename: 046904_eng.pdf

Refer to "General Notes Relating to Pepperl+Fuchs Product Information".

Pepperl+Fuchs Group
www.pepperl-fuchs.com

USA: +1 330 486 0002
pa-info@us.pepperl-fuchs.com

Germany: +49 621 776 2222
pa-info@de.pepperl-fuchs.com

Singapore: +65 6779 9091
pa-info@sg.pepperl-fuchs.com

 **PEPPERL+FUCHS**

Technical Data

Safety Integrity Level (SIL)		SIL 3
Systematic capability (SC)		SC 3
Performance level (PL)		PL d
Supply		
Connection		terminals 22, 23, 24
Rated voltage	U_r	85 ... 253 V AC , 45 ... 65 Hz
Rated current	I_r	30 mA \pm 5 mA
Power dissipation		2.2 W
Power consumption		max. 2.3 W
Input		
Connection side		field side
Connection		terminals 10+, 12-
Open circuit voltage/short-circuit current		approx. 8.4 V DC / approx. 11.7 mA
Lead resistance		$\leq 50 \Omega$, in hazardous area cable capacitances and inductivities are to be taken into account
Switching point		
Relay de-energized		$I < 2.1 \text{ mA}$ and $I > 5.9 \text{ mA}$
Relay energized		$2.8 \text{ mA} < I < 5.3 \text{ mA}$
Response delay		$\leq 1 \text{ ms}$
Output		
Connection side		control side
Connection		output I: terminals 13, 14 ; output II: terminals 15, 21 ; output III: terminals 16+, 17-
Output I		relay , signal
Contact loading		253 V AC/1 A/cos $\phi \geq 0.7$; 24 V DC/1 A resistive load
Mechanical life		50×10^6 switching cycles
Output II		relay , signal
Contact loading		253 V AC/1 A/cos $\phi \geq 0.7$; 24 V DC/1 A resistive load
Mechanical life		50×10^6 switching cycles
Output III		electronic output, passive , fault signal
Rated voltage		10 ... 30 V DC
Signal level		1-signal: (L+) -2.5 V (7 mA, short-circuit proof) / 0-signal: blocked output (Leakage current $\leq 10 \mu\text{A}$)
Transfer characteristics		
Switching frequency		5 Hz
Indicators/settings		
Display elements		LEDs
Labeling		space for labeling at the front
Directive conformity		
Electromagnetic compatibility		
Directive 2014/30/EU		EN 61326-1:2013 (industrial locations)
Low voltage		
Directive 2014/35/EU		EN 61010-1:2010+A1:2019+A1:2019/AC:2019
Machinery Directive		
Directive 2006/42/EC		EN/ISO 13849-1:2015
Conformity		
Electromagnetic compatibility		NE 21:2017 , EN 61326-3-1:2017
Degree of protection		IEC 60529:2001
Safety		IEC/EN 61508:2010
Ambient conditions		
Ambient temperature		-20 ... 60 °C (-4 ... 140 °F)
Mechanical specifications		
Degree of protection		IP20
Connection		screw terminals
Mass		approx. 280 g

Release date: 2025-02-04 Date of issue: 2025-02-04 Filename: 046904_eng.pdf

Refer to "General Notes Relating to Pepperl+Fuchs Product Information".

Pepperl+Fuchs Group
www.pepperl-fuchs.comUSA: +1 330 486 0002
pa-info@us.pepperl-fuchs.comGermany: +49 621 776 2222
pa-info@de.pepperl-fuchs.comSingapore: +65 6779 9091
pa-info@sg.pepperl-fuchs.com

PEPPERL+FUCHS

Technical Data

Dimensions	40 x 93 x 115 mm (1.6 x 3.7 x 4.5 inch) (W x H x D) , housing type E	
Mounting	on 35 mm DIN mounting rail acc. to EN 60715:2001	
Data for application in connection with hazardous areas		
EU-type examination certificate	PTB 00 ATEX 2043	
Marking	Ⓢ II (1)G [Ex ia Ga] IIC Ⓢ II (1)D [Ex ia Da] IIIC Ⓢ I (M1) [Ex ia Ma] I	
Input	Ex ia	
Voltage	U _o	9.56 V
Current	I _o	16.8 mA
Power	P _o	41 mW (linear characteristic)
Supply		
Maximum safe voltage	U _m	253 V AC/DC (Attention! The rated voltage can be lower.)
Output		
Contact loading	253 V AC/1 A/cos φ ≥ 0.7; 24 V DC/1 A resistive load	
Maximum safe voltage	U _m	output I/output II: 253 V AC/DC (Attention! U _m is no rated voltage.)
Galvanic isolation		
Input/Output	safe electrical isolation acc. to IEC/EN 60079-11, voltage peak value 375 V	
Input/power supply	safe electrical isolation acc. to IEC/EN 60079-11, voltage peak value 375 V	
Directive conformity		
Directive 2014/34/EU	EN IEC 60079-0:2018+AC:2020 , EN 60079-11:2012	
General information		
Supplementary information	Observe the certificates, declarations of conformity, instruction manuals, and manuals where applicable. For information see www.pepperl-fuchs.com .	

Assembly

Front view

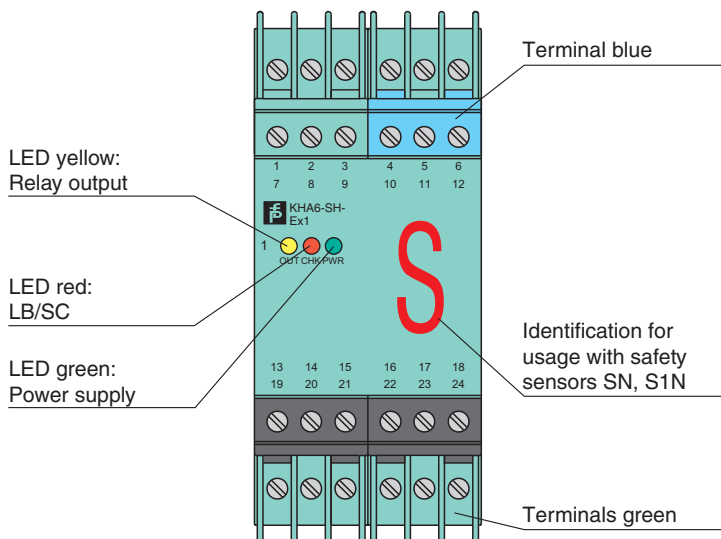

Release date: 2025-02-04 Date of issue: 2025-02-04 Filename: 046904_eng.pdf

Characteristic Curve

Maximal switching power of the output

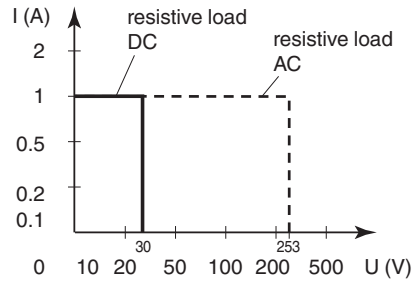

Release date: 2025-02-04 Date of issue: 2025-02-04 Filename: 046904_eng.pdf

Refer to "General Notes Relating to Pepperl+Fuchs Product Information".

Pepperl+Fuchs Group
www.pepperl-fuchs.com

USA: +1 330 486 0002
pa-info@us.pepperl-fuchs.com

Germany: +49 621 776 2222
pa-info@de.pepperl-fuchs.com

Singapore: +65 6779 9091
pa-info@sg.pepperl-fuchs.com

pf PEPPERL+FUCHS