



# SMART Transmitter Power Supply

## KFD2-STC5-Ex2

- 2-channel isolated barrier
- 24 V DC supply (Power Rail)
- Input 2-wire and 3-wire SMART transmitters and 2-wire SMART current sources
- Output 4 mA ... 20 mA current sink/current source
- Terminals with test points
- Up to SIL 2 (SC 3) acc. to IEC/EN 61508



### Function

This isolated barrier is used for intrinsic safety applications. The device supplies 2-wire and 3-wire SMART transmitters, and can also be used with 2-wire SMART current sources. It transfers the analog input signal to the safe area as an isolated current value. Digital signals may be superimposed on the input signal in the hazardous or non-hazardous area and are transferred bi-directionally. The device provides a sink mode or a source mode output on the safe area terminals. The device has an internal resistor. Use this resistor if the HART communication resistance in the control circuit is too low. Test sockets for the connection of HART communicators are integrated into the terminals of the device.

### Application

The device supports the following SMART protocols:

- HART
- BRAIN
- Foxboro

### Wiring Diagram

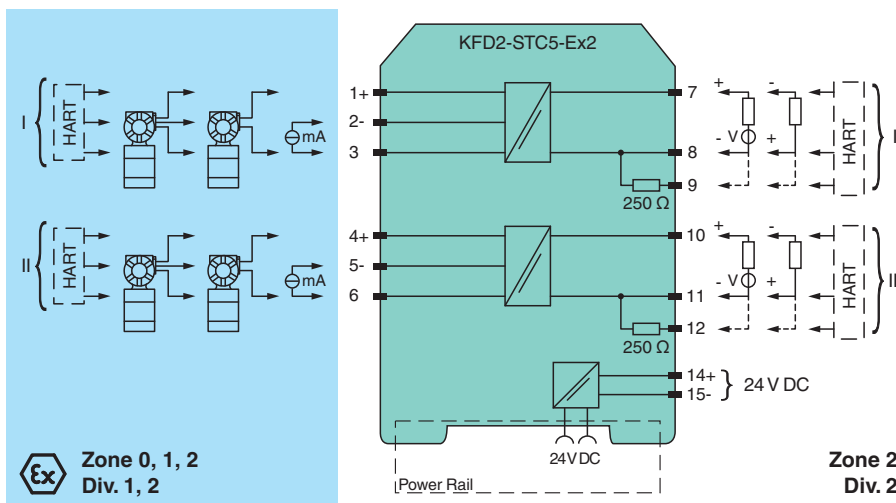

### Technical Data

<b>General specifications</b>	
Signal type	Analog input
<b>Functional safety related parameters</b>	
Safety Integrity Level (SIL)	SIL 2
Systematic capability (SC)	SC 3

Release date: 2026-03-05 Date of issue: 2026-03-05 Filename: 203645\_eng.pdf

Refer to "General Notes Relating to Pepperl+Fuchs Product Information".

Pepperl+Fuchs Group  
www.pepperl-fuchs.com

USA: +1 330 486 0002  
pa-info@us.pepperl-fuchs.com

Germany: +49 621 776 2222  
pa-info@de.pepperl-fuchs.com

Singapore: +65 6779 9091  
pa-info@sg.pepperl-fuchs.com

**PEPPERL+FUCHS**

## Technical Data

<b>Supply</b>		
Connection		Power Rail or terminals 14+, 15-
Rated voltage	$U_r$	18 ... 30 V DC
Ripple		within the supply tolerance
Power dissipation		≤ 1.4 W at maximum load
Power consumption		≤ 2.6 W at maximum load
<b>Input</b>		
Connection side		field side
Connection		terminals 1+, 2-, 3; 4+, 5-, 6
Input signal		4 ... 20 mA
Open circuit voltage/short-circuit current		terminals 1+, 3; 4+, 6: 23 V / 25 mA
Input resistance		max. 265 Ω terminals 2-, 3; 5-, 6, max. 330 Ω terminals 1+, 3; 4+, 6
Available voltage		≥ 16 V at 20 mA ; ≥ 20 V at 4 mA, terminals 1+, 3; 4+, 6
<b>Output</b>		
Connection side		control side
Connection		terminals 7+, 8-, 9-; 10+, 11-, 12- (sink) terminals 7-, 8+, 9+; 10-, 11+, 12+ (source) see additional information
Load		0 ... 600 Ω
Output signal		4 ... 20 mA (overload > 25 mA)
Ripple		max. 50 μA <sub>rms</sub>
External supply (loop)		2 ... 30 V DC If the external voltage is > 19 V, a load ≥ ((V - 19) / 0.02) Ω is required. V represents the value of the external voltage. The internal 250 Ω resistor at terminals 9 and 12 can be used as a load.
<b>Transfer characteristics</b>		
Deviation		at 20 °C (68 °F), 4 ... 20 mA ≤ 10 μA incl. calibration, linearity, hysteresis, loads and fluctuations of supply voltage
Influence of ambient temperature		≤ 0.25 μA/K
Frequency range		field side into the control side: band width with 1 V <sub>pp</sub> signal 0 ... 7.5 kHz (-3 dB) safe area to hazardous area: band width with 1 V <sub>SS</sub> signal 0.3 ... 7.5 kHz (-3 dB)
Settling time		200 μs
Rise time/fall time		100 μs
<b>Galvanic isolation</b>		
Output/power supply		functional insulation, rated insulation voltage 50 V AC
Output/Output		functional insulation, rated insulation voltage 50 V AC
<b>Indicators/settings</b>		
Display elements		LED
Labeling		space for labeling at the front
<b>Directive conformity</b>		
Electromagnetic compatibility		
Directive 2014/30/EU		EN 61326-1:2013 (industrial locations)
<b>Conformity</b>		
Electromagnetic compatibility		NE 21:2012 EN 61326-3-2:2008
Degree of protection		IEC 60529:2001
Protection against electrical shock		UL 61010-1:2012
<b>Ambient conditions</b>		
Ambient temperature		-20 ... 60 °C (-4 ... 140 °F) extended ambient temperature range up to 70 °C (158 °F), refer to manual for necessary mounting conditions
<b>Mechanical specifications</b>		
Degree of protection		IP20
Connection		screw terminals
Mass		approx. 200 g
Dimensions		20 x 124 x 115 mm (0.8 x 4.9 x 4.5 inch) (W x H x D), housing type B2
Mounting		on 35 mm DIN mounting rail acc. to EN 60715:2001

Release date: 2026-03-05 Date of issue: 2026-03-05 Filename: 203645\_eng.pdf

Refer to "General Notes Relating to Pepperl+Fuchs Product Information".

Pepperl+Fuchs Group  
www.pepperl-fuchs.comUSA: +1 330 486 0002  
pa-info@us.pepperl-fuchs.comGermany: +49 621 776 2222  
pa-info@de.pepperl-fuchs.comSingapore: +65 6779 9091  
pa-info@sg.pepperl-fuchs.com

**PEPPERL+FUCHS**

## Technical Data

Data for application in connection with hazardous areas		
EU-type examination certificate		CML 17 ATEX 2031X
Marking		Ⓜ II (1)G [Ex ia Ga] IIC Ⓜ II (1)D [Ex ia Da] IIIC Ⓜ I (M1) [Ex ia Ma] I
Input		[Ex ia Ga] IIC, [Ex ia Da] IIIC, [Ex ia Ma] I
Supply		
Maximum safe voltage	$U_m$	250 V (Attention! The rated voltage can be lower.)
Equipment		terminals 1+, 3-; 4+, 6-
Voltage	$U_o$	26.2 V
Voltage	$U_q$	27.25 V
Current	$I_o$	93 mA
Power	$P_o$	634 mW
Equipment		terminals 2-, 3+; 5-, 6+
Voltage	$U_i$	30 V
Current	$I_i$	115 mA
Power	$P_i$	max 1 W
Voltage	$U_o$	2 V
Current	$I_o$	8.5 mA
Power	$P_o$	4.3 mW
Equipment		terminals 1+, 2/3-; 4+, 5/6-
Voltage	$U_o$	26.2 V
Voltage	$U_q$	27.25 V
Current	$I_o$	115 mA
Power	$P_o$	784 mW
Certificate		CML 17 ATEX 3030X
Marking		Ⓜ II 3G Ex ec IIC T4 Gc
Galvanic isolation		
Input/Output		safe electrical isolation acc. to IEC/EN 60079-11:2007, voltage peak value 375 V
Input/power supply		safe electrical isolation acc. to IEC/EN 60079-11:2007, voltage peak value 375 V
Directive conformity		
Directive 2014/34/EU		EN IEC 60079-0:2018+AC:2020 , EN 60079-7:2015+A1:2018 , EN 60079-11:2012
International approvals		
UL approval		E106378
Control drawing		116-0439 (cULus)
IECEx approval		
IECEx certificate		IECEx CML 17.0016X
IECEx marking		[Ex ia Ga] IIC , [Ex ia Da] IIIC , [Ex ia Ma] I Ex ec IIC T4 Gc
General information		
Supplementary information		Observe the certificates, declarations of conformity, instruction manuals, and manuals where applicable. For information see <a href="http://www.pepperl-fuchs.com">www.pepperl-fuchs.com</a> .

Release date: 2026-03-05 Date of issue: 2026-03-05 Filename: 203645\_eng.pdf

**Assembly**

Front view

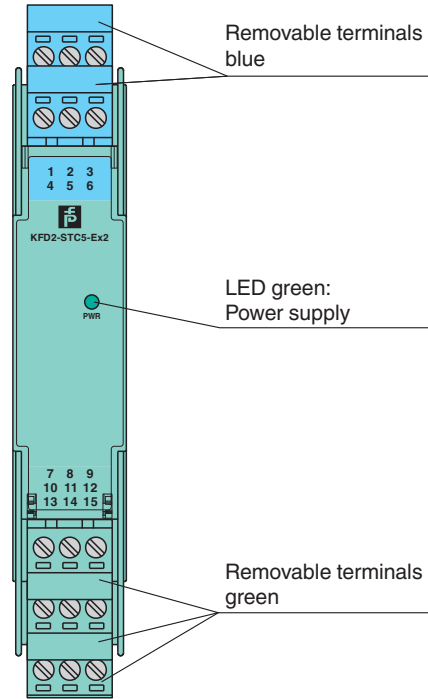

**Connection**

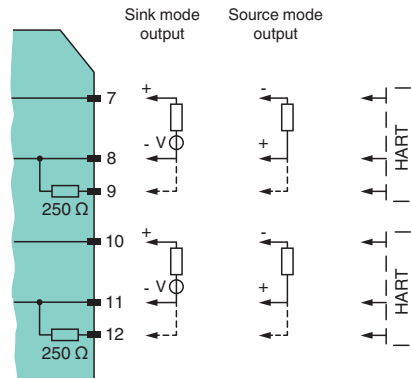

The device provides 2 outputs on the control side terminals. These outputs can be operated in any combination of the current sink operating mode and current source operating mode. Please refer to the connection diagram.

Release date: 2026-03-05 Date of issue: 2026-03-05 Filename: 203645\_eng.pdf