



Switch Amplifier

HiC2853R4

- 1-channel isolated barrier
- 24 V DC supply (bus powered)
- Input for approved dry contacts or SN/S1N sensors
- Usable as signal splitter (1 input and 2 outputs)
- Application-specific outputs
- Active voltage output
- Passive transistor output (resistive)
- Line fault detection (LFD)
- Line fault transparency (LFT)
- Up to SIL 3 acc. to IEC/EN 61508



Function

This isolated barrier is used for intrinsic safety applications. The device transfers digital signals (SN/S1N proximity sensors or approved dry contacts) from the explosion-hazardous area to the non-explosion-hazardous area. The input controls one active voltage output and one passive transistor output with a resistive output characteristic. The passive transistor output has three defined states: 1-signal = 472 Ω, 0-signal = 1385 Ω and fault > 100 kΩ. This output characteristic offers line fault transparency on the signal lines. During a fault state, both outputs switch to their fault state and LEDs indicate the fault according to NAMUR NE 44. A separate fault bus is available. This fault bus can be monitored if the termination board supports a module fault detection. Unlike a SN/S1N series safety sensor, an approved dry contact requires a 10 kΩ resistor to be placed across the contact in addition to a 1.5 kΩ resistor in series. This device mounts on a HiC termination board.

Application

This device is compatible to the control:

- Schneider Electric Tricon-CX 3902(A)X

Compatibility check to other ESD/ DCS systems on request.

Connection

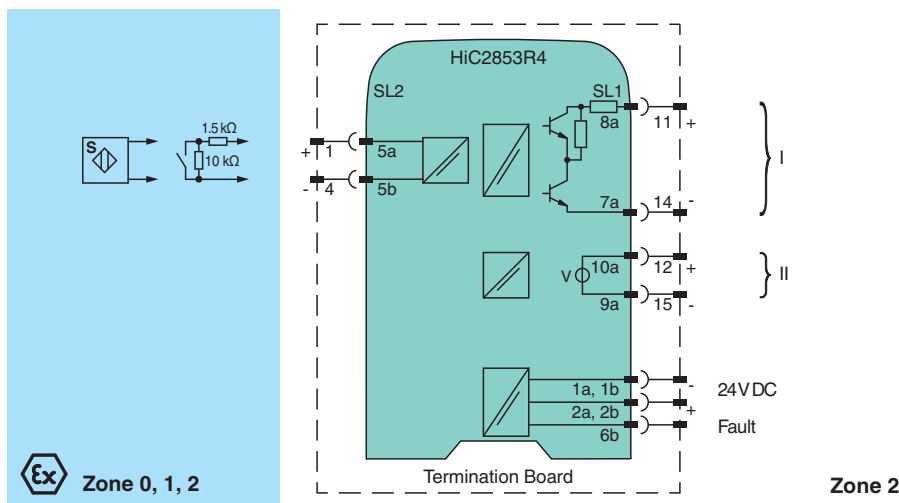

Technical Data

General specifications	
Signal type	Digital Input
Functional safety related parameters	

Release date: 2023-06-05 Date of issue: 2023-06-05 Filename: 70142832_eng.pdf

Refer to "General Notes Relating to Pepperl+Fuchs Product Information".

Pepperl+Fuchs Group
www.pepperl-fuchs.com

USA: +1 330 486 0002
pa-info@us.pepperl-fuchs.com

Germany: +49 621 776 2222
pa-info@de.pepperl-fuchs.com

Singapore: +65 6779 9091
pa-info@sg.pepperl-fuchs.com

PF PEPPERL+FUCHS

Technical Data

Safety Integrity Level (SIL)		SIL 3
Systematic capability (SC)		SC 3
Supply		
Connection		SL1: 1a(-), 1b(-); 2a(+), 2b(+)
Rated voltage	U_r	19 ... 30 V DC bus powered via Termination Board
Ripple		$\leq 10 \%$
Rated current	I_r	$\leq 55 \text{ mA}$
Power dissipation		$\leq 800 \text{ mW}$
Power consumption		$\leq 1300 \text{ mW}$
Input		
Connection side		field side
Connection		SL2: 5a(+), 5b(-)
Open circuit voltage/short-circuit current		approx. 8.4 V DC / approx. 11.9 mA
Switching point/switching hysteresis		2.1 ... 2.8 mA / approx. 0.3 mA
Line fault detection		breakage $I \leq 0.15 \text{ mA}$, short-circuit $I \geq 8.5 \text{ mA}$
Pulse/Pause ratio		
Lead resistance		max. 50 Ω , consider capacitances and inductances
Switching point		1-signal: $I > 2.8 \text{ mA}$ 0-signal: $I < 2.1 \text{ mA}$
Response delay		$\leq 1 \text{ ms}$
Output		
Connection side		control side
Connection		SL1: 8a(+), 7a(-); 10a(+), 9a(-)
Nominal current	I_{in}	output I: 10 mA $\pm 1 \%$
Output I		passive transistor output (resistive) 0-signal: 1385 $\Omega \pm 4 \%$ 1-signal: 472 $\Omega \pm 4 \%$ fault: > 100 k Ω ; Current source requires suitable voltage limitation.
Output II		active voltage output, short-circuit proof 0-signal: 0 V 1-signal: 20 ... 31 V DC at max. 15 mA fault: 0 V
Fault indication output		
Connection		SL1: 6b
Output type		open collector transistor (internal fault bus)
Transfer characteristics		
Switching frequency		
Output I		$\leq 50 \text{ Hz}$
Output II		$\leq 50 \text{ Hz}$
Galvanic isolation		
Output/power supply		functional insulation acc. to IEC 62103, rated insulation voltage 50 V _{eff}
Output/Output		functional insulation acc. to IEC 62103, rated insulation voltage 50 V _{eff}
Indicators/settings		
Display elements		LEDs
Labeling		space for labeling at the front
Directive conformity		
Electromagnetic compatibility		
Directive 2014/30/EU		EN 61326-1:2013 (industrial locations)
Conformity		
Electromagnetic compatibility		EN IEC 61326-3-2:2018 , NE 21:2017 For further information see system description.
Degree of protection		IEC 60529:2001
Ambient conditions		
Ambient temperature		-20 ... 60 °C (-4 ... 140 °F)
Mechanical specifications		
Degree of protection		IP20

Release date: 2023-06-05 Date of issue: 2023-06-05 Filename: 70142832_eng.pdf

Refer to "General Notes Relating to Pepperl+Fuchs Product Information".

 Pepperl+Fuchs Group
www.pepperl-fuchs.com

 USA: +1 330 486 0002
pa-info@us.pepperl-fuchs.com

 Germany: +49 621 776 2222
pa-info@de.pepperl-fuchs.com

 Singapore: +65 6779 9091
pa-info@sg.pepperl-fuchs.com

 **PEPPERL+FUCHS**

Technical Data

Mass	approx. 105 g	
Dimensions	12.5 x 106 x 128 mm (0.5 x 4.2 x 5.1 inch) (W x H x D)	
Mounting	on termination board	
Coding	pin 1 and 2 trimmed For further information see system description.	
Data for application in connection with hazardous areas		
EU-type examination certificate	BASEEFA 07 ATEX 0302X	
Marking	Ⓜ II (1)G [Ex ia] IIC , Ⓜ II (1) D [Ex ia] IIIC , Ⓜ I (M1) [Ex ia] I	
Input	Ex ia	
Voltage	U _o	10.5 V
Current	I _o	17.1 mA
Power	P _o	45 mW (linear characteristic)
Supply		
Maximum safe voltage	U _m	253 V AC (Attention! U _m is no rated voltage.)
Output		
Maximum safe voltage	U _m	253 V AC (Attention! U _m is no rated voltage.)
Certificate	PF 09 CERT 1440 X	
Marking	Ⓜ II 3G Ex nA IIC T4 Gc	
Galvanic isolation		
Input/Output	safe electrical isolation acc. to IEC/EN 60079-11, voltage peak value 375 V	
Input/power supply	safe electrical isolation acc. to IEC/EN 60079-11, voltage peak value 375 V	
Directive conformity		
Directive 2014/34/EU	EN IEC 60079-0:2018+AC:2020 , EN 60079-11:2012 , EN 60079-15:2010	
International approvals		
UL approval	E106378	
Control drawing	116-0364	
IECEx approval		
IECEx certificate	IECEx BAS 07.0097X	
IECEx marking	[Ex ia Ga] IIC, [Ex ia] IIIC , [Ex ia] I	
General information		
Supplementary information	Observe the certificates, declarations of conformity, instruction manuals, and manuals where applicable. For information see www.pepperl-fuchs.com .	

Assembly

Front view

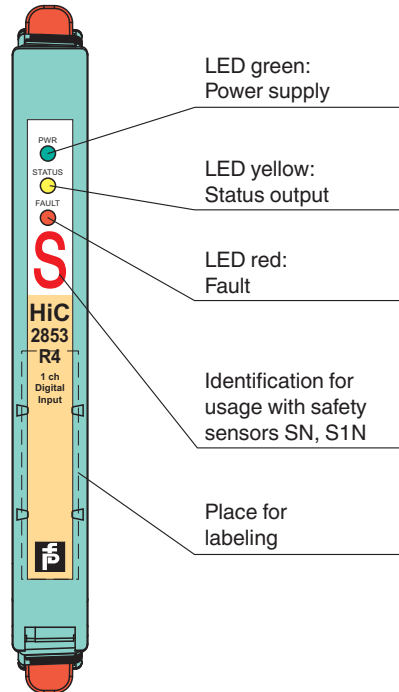

Safety Information

The pins for this device are trimmed to polarize it according to its safety parameter. Do not change this setting!
For further information see system manual.

Configuration

No user configuration available for this device.

Characteristic Curve

Switch points

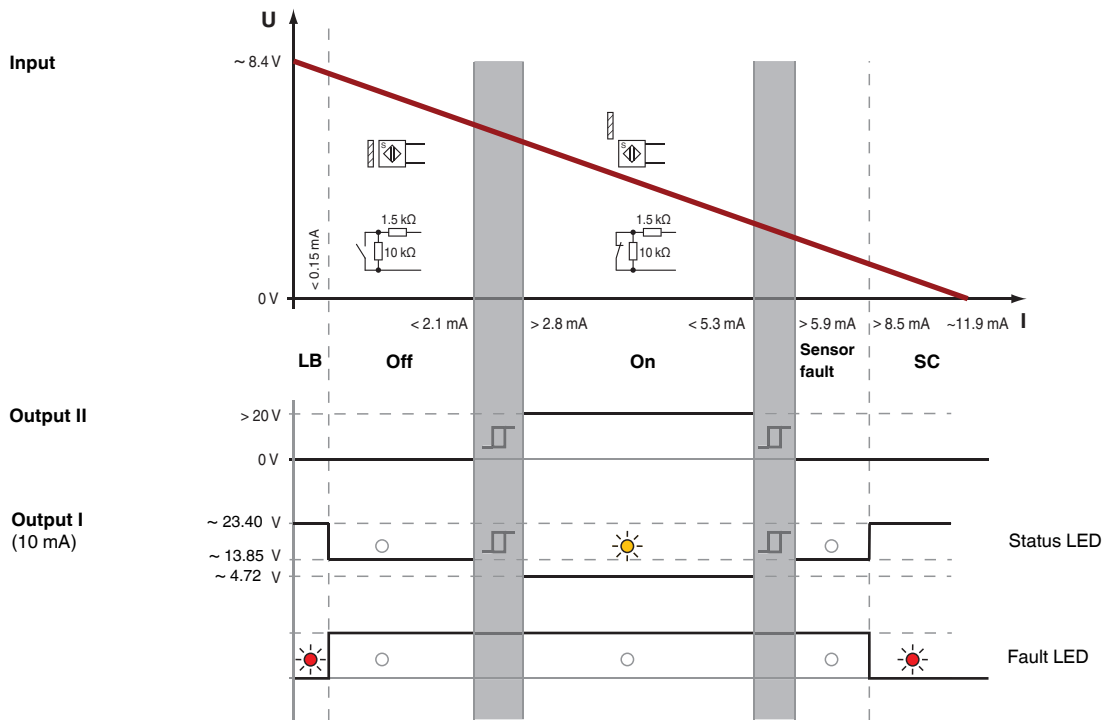

Release date: 2023-06-05 Date of issue: 2023-06-05 Filename: 70142832_eng.pdf

Refer to "General Notes Relating to Pepperl+Fuchs Product Information".

Pepperl+Fuchs Group
www.pepperl-fuchs.com

USA: +1 330 486 0002
pa-info@us.pepperl-fuchs.com

Germany: +49 621 776 2222
pa-info@de.pepperl-fuchs.com

Singapore: +65 6779 9091
pa-info@sg.pepperl-fuchs.com

PEPPERL+FUCHS