



SMART Current Driver

HiC2031

- 1-channel isolated barrier
- 24 V DC supply (bus powered)
- Current output up to 650 Ω load
- Low power dissipation
- Up to SIL 2 (SC 3) acc. to IEC/EN 61508



Function

This isolated barrier is used for intrinsic safety applications. It repeats the input signal from a control system to drive HART I/P converters, valve actuators, and displays located in a hazardous area. Digital signals are superimposed on the analog values at the field side or control side and are transferred bi-directionally. An open field circuit presents a high impedance to the control side to allow alarm conditions to be monitored by the control system. This device mounts on a HiC termination board.

Wiring Diagram

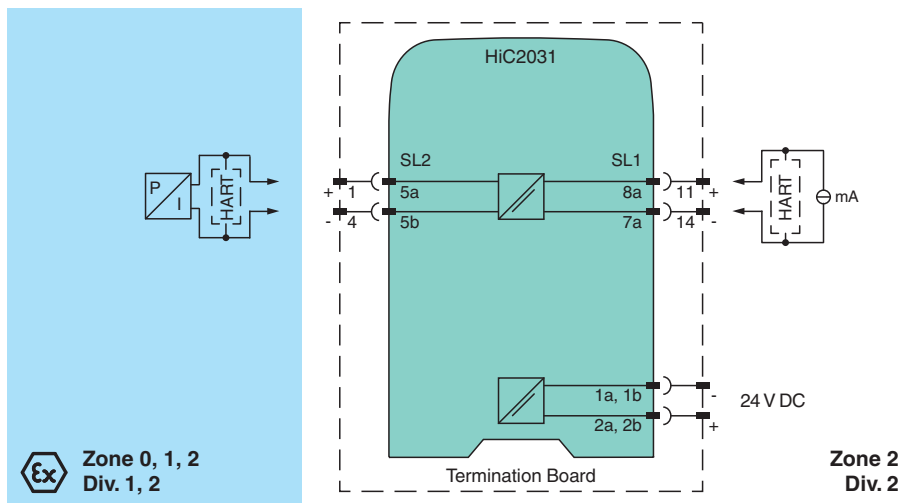

Technical Data

General specifications	
Signal type	Analog output
Functional safety related parameters	
Safety Integrity Level (SIL)	SIL 2
Systematic capability (SC)	SC 3
Supply	
Connection	SL1: 1a(-), 1b(-); 2a(+), 2b(+)
Rated voltage	U _r 19 ... 30 V DC bus powered via Termination Board

Release date: 2025-09-16 Date of issue: 2025-09-16 Filename: 70150448_eng.pdf

Refer to "General Notes Relating to Pepperl+Fuchs Product Information".

Pepperl+Fuchs Group
www.pepperl-fuchs.com

USA: +1 330 486 0002
pa-info@us.pepperl-fuchs.com

Germany: +49 621 776 2222
pa-info@de.pepperl-fuchs.com

Singapore: +65 6779 9091
pa-info@sg.pepperl-fuchs.com



Technical Data

Ripple		≤ 10 %
Rated current	I_r	≤ 30 mA at 24 V
Power dissipation		≤ 600 mW at 20 mA and 500 Ω load
Power consumption		≤ 700 mW
Input		
Connection side		control side
Connection		SL1: 8a(+), 7a(-)
Input signal		4 ... 20 mA, limited to approx. 26 mA
Input voltage		open loop voltage of the control system < 30 V
Voltage drop		approx. 6 V at 20 mA
Input resistance		> 100 kΩ, with field wiring open
Output		
Connection side		field side
Connection		SL2: 5a(+), 5b(-)
Voltage		≥ 13 V at 20 mA
Current		4 ... 20 mA
Load		0 ... 650 Ω
Ripple		20 mV rms
Transfer characteristics		
Deviation		at 20 °C (68 °F), 4 ... 20 mA < 0.1 % of full scale, incl. non-linearity and hysteresis
Influence of ambient temperature		< 2 μA/K (-20 ... 70 °C (-4 ... 158 °F)); < 4 μA/K (-40 ... -20 °C (-40 ... -4 °F))
Frequency range		field side into the control side: bandwidth with 0.5 V _{pp} signal 0 ... 3 kHz (-3 dB) control side into the field side: bandwidth with 1 mA _{pp} signal 0 ... 3 kHz (-3 dB)
Rise time		10 to 90 % ≤ 10 ms
Galvanic isolation		
Input/Output		safe electrical isolation acc. to IEC/EN 60079-11, voltage peak value 375 V
Input/power supply		basic insulation according to IEC/EN 61010-1, rated insulation voltage 60 V _{eff}
Output/power supply		safe electrical isolation acc. to IEC/EN 60079-11, voltage peak value 375 V
Indicators/settings		
Display elements		LED
Labeling		space for labeling at the front
Directive conformity		
Electromagnetic compatibility		
Directive 2014/30/EU		EN 61326-1:2013 (industrial locations)
Conformity		
Electromagnetic compatibility		NE 21:2017 EN 61326-3-2:2018 For further information see system description.
Degree of protection		IEC 60529:2001
Protection against electrical shock		UL 61010-1:2018
Ambient conditions		
Ambient temperature		-40 ... 70 °C (-40 ... 158 °F)
Mechanical specifications		
Degree of protection		IP20
Mass		approx. 100 g
Dimensions		12.5 x 106 x 128 mm (0.5 x 4.2 x 5.1 inch) (W x H x D)
Mounting		on termination board
Coding		pin 1 and 3 trimmed For further information see system description.
Data for application in connection with hazardous areas		
EU-type examination certificate		CESI 06 ATEX 017
Marking		⊕ II (1)G [Ex ia Ga] IIC ⊕ II (1)D [Ex ia Da] IIIC ⊕ I (M1) [Ex ia Ma] I
Output		Ex ia

Release date: 2025-09-16 Date of issue: 2025-09-16 Filename: 70150448_eng.pdf

Refer to "General Notes Relating to Pepperl+Fuchs Product Information".

 Pepperl+Fuchs Group
www.pepperl-fuchs.com

 USA: +1 330 486 0002
pa-info@us.pepperl-fuchs.com

 Germany: +49 621 776 2222
pa-info@de.pepperl-fuchs.com

 Singapore: +65 6779 9091
pa-info@sg.pepperl-fuchs.com

 PEPPERL+FUCHS

Technical Data

Supply			
Maximum safe voltage	U_m	250 V AC (Attention! U_m is no rated voltage.)	
Equipment			
Voltage	U_o	25.2 V	
Current	I_o	100 mA	
Power	P_o	630 mW	
Internal capacitance	C_i	5.7 nF	
Internal inductance	L_i	negligible	
Certificate			
CESI 19 ATEX 027 X			
Marking			
Ⓜ II 3G Ex ec IIC T4 Gc			
Directive conformity			
Directive 2014/34/EU EN IEC 60079-0:2018 , EN 60079-11:2012 , EN IEC 60079-7:2015/A1:2018			
International approvals			
FM approval			
FM certificate FM 19 US 0122 X , FM 19 CA 0065 X			
Control drawing 116-0470 (cFMus)			
UL approval			
Control drawing E106378			
Control drawing 116-0458 (cULus)			
IECEX approval			
IECEX certificate IECEX CES 06.0002X			
IECEX marking [Ex ia Ga] IIC , [Ex ia Da] IIIC , [Ex ia Ma] I Ex ec IIC T4 Gc			
General information			
Supplementary information Observe the certificates, declarations of conformity, instruction manuals, and manuals where applicable. For information see www.pepperl-fuchs.com .			

Assembly

Front view

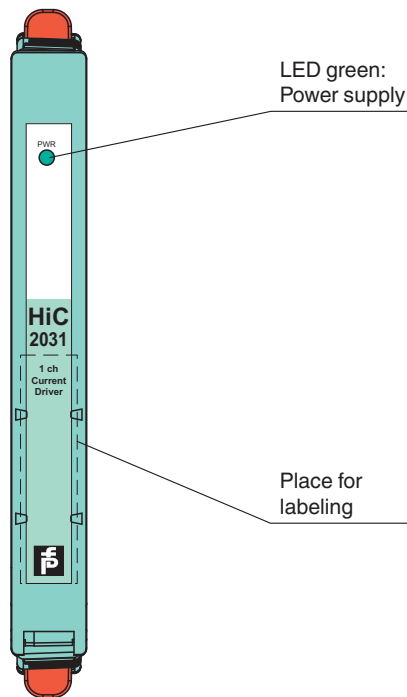

Safety Information

The pins for this device are trimmed to polarize it according to its safety parameter. Do not change this setting!
For further information see system manual.

Release date: 2025-09-16 Date of issue: 2025-09-16 Filename: 70150448_eng.pdf

Refer to "General Notes Relating to Pepperl+Fuchs Product Information".