



Solenoid Driver KFD2-SL2-Ex2

- 2-channel isolated barrier
- 24 V DC supply (Power Rail)
- Output 45 mA at 11.7 V DC
- Logic input, non-polarized
- Line fault detection (LFD)
- Up to SIL 2 acc. to IEC/EN 61508



Function

This isolated barrier is used for intrinsic safety applications. The device supplies power to solenoids, LEDs and audible alarms located in a hazardous area. It is controlled via logic signals. The inputs have two defined states: 1-Signal = 16 V DC ... 30 V DC, 0-Signal = 0 V DC ... 5 V DC. The current consumption of the input is about 3 mA. At full load, 11.7 V at 45 mA is available for the hazardous area application. If the field impedance is > 10 kΩ for lead breakage or < 50 Ω for short circuits a line fault is detected. A fault is signaled by LEDs and a separate collective error message output.

Wiring Diagram

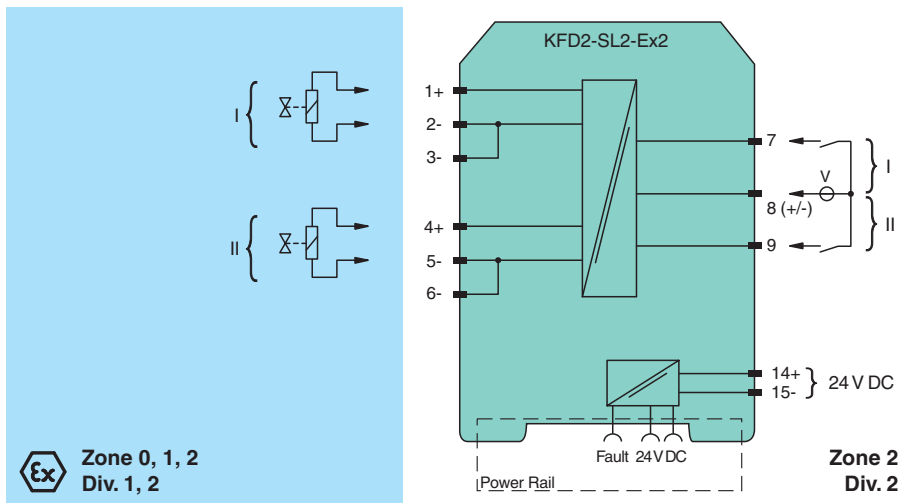

Technical Data

General specifications	
Signal type	Digital Output
Functional safety related parameters	
Safety Integrity Level (SIL)	SIL 2
Supply	
Connection	Power Rail or terminals 14+, 15-
Rated voltage	U _r 20 ... 30 V DC
Power consumption	max. 3.3 W at 45 mA output current
Input	
Connection side	control side

Release date: 2026-03-26 Date of issue: 2026-03-26 Filename: 70180149_eng.pdf

Refer to "General Notes Relating to Pepperl+Fuchs Product Information".

Pepperl+Fuchs Group
www.pepperl-fuchs.com

USA: +1 330 486 0002
pa-info@us.pepperl-fuchs.com

Germany: +49 621 776 2222
pa-info@de.pepperl-fuchs.com

Singapore: +65 6779 9091
pa-info@sg.pepperl-fuchs.com

PF PEPPERL+FUCHS

Technical Data

Connection		terminals 7, 8, 9
Input current		approx. 3 mA at 24 V DC
Signal level		1-signal: 16 ... 30 V DC 0-signal: 0 ... 5 V DC
Output		
Connection side		field side
Connection		channel 1: terminals 1+, 2-, 3 channel 2: terminals 4+, 5-, 6-
Internal resistor	R_i	272 Ω
Current	I_e	≤ 45 mA
Voltage	U_e	≥ 11.7 V
Current limit	I_{max}	45 mA
Open loop voltage	U_s	min. 24 V
Output signal		These values are valid for the rated operating voltages from 20 ... 30 V DC.
Energized/De-energized delay		≤ 20 ms / ≤ 20 ms
Line fault detection		
Test current		max. 650 μ A , calculated by $I_{LFD} = 25 \text{ V} / (39 \text{ k}\Omega + R_{Load})$
Galvanic isolation		
Input/Output		reinforced insulation according to IEC/EN 61010-1, rated insulation voltage 300 V _{eff}
Input/power supply		reinforced insulation according to IEC/EN 61010-1, rated insulation voltage 300 V _{eff}
Power supply/Output		reinforced insulation according to IEC/EN 61010-1, rated insulation voltage 300 V _{eff}
Indicators/settings		
Display elements		LEDs
Control elements		DIP switch
Configuration		via DIP switches
Labeling		space for labeling at the front
Directive conformity		
Electromagnetic compatibility		
Directive 2014/30/EU		EN 61326-1:2013 (industrial locations)
Conformity		
Electromagnetic compatibility		NE 21:2006
Degree of protection		IEC 60529:2001
Protection against electrical shock		EN 61010-1:2010
Ambient conditions		
Ambient temperature		-20 ... 50 °C (-4 ... 122 °F)
Mechanical specifications		
Degree of protection		IP20
Connection		screw terminals
Mass		approx. 150 g
Dimensions		20 x 119 x 115 mm (0.8 x 4.7 x 4.5 inch) (W x H x D) , housing type B2
Mounting		on 35 mm DIN mounting rail acc. to EN 60715:2001
Data for application in connection with hazardous areas		
EU-type examination certificate		ZELM 00 ATEX 0024
Marking		Ⓜ II (1)G [Ex ia Ga] IIC Ⓜ II (1)D [Ex ia Da] IIIC Ⓜ I (M1) [Ex ia Ma] I
Output		Ex ia
Voltage	U_o	28 V
Current	I_o	110 mA
Power	P_o	770 mW (linear characteristic)
Supply		
Maximum safe voltage	U_m	40 V (Attention! The rated voltage can be lower.)
Input		
Maximum safe voltage	U_m	60 V (Attention! The rated voltage can be lower.)

Release date: 2026-03-26 Date of issue: 2026-03-26 Filename: 70180149_eng.pdf

Technical Data

Collective error message		
Maximum safe voltage	U _m	40 V (Attention! The rated voltage can be lower.)
Certificate		TÜV 02 ATEX 1820 X
Marking		Ⓔ II 3G Ex nA IIC T4 Gc
Galvanic isolation		
Input/Output		safe electrical isolation acc. to IEC/EN 60079-11, voltage peak value 375 V
Output/power supply		safe electrical isolation acc. to IEC/EN 60079-11, voltage peak value 375 V
Directive conformity		
Directive 2014/34/EU		EN IEC 60079-0:2018+AC:2020 , EN 60079-11:2012 , EN 60079-15:2010 , EN 50303:2000
International approvals		
CSA approval		
Control drawing		116-0304
IECEX approval		
IECEX certificate		IECEX TUN 04.0001
IECEX marking		[Ex ia Ga] IIC, [Ex ia Da] IIIC, [Ex ia Ma] I
General information		
Supplementary information		Observe the certificates, declarations of conformity, instruction manuals, and manuals where applicable. For information see www.pepperl-fuchs.com .

Assembly

Front view

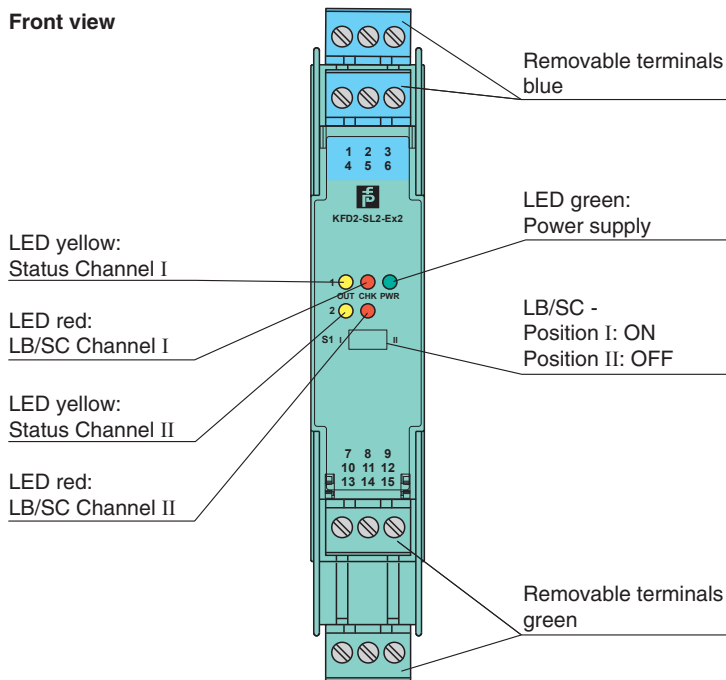

Release date: 2026-03-26 Date of issue: 2026-03-26 Filename: 70180149_eng.pdf

Characteristic Curve

Output characteristics

Output circuit diagram

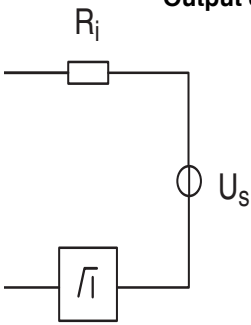

Output characterist

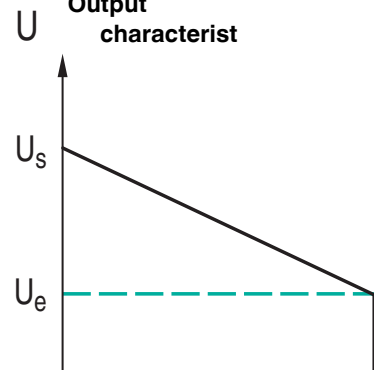

Release date: 2026-03-26 Date of issue: 2026-03-26 Filename: 70180149_eng.pdf

Refer to "General Notes Relating to Pepperl+Fuchs Product Information".

Pepperl+Fuchs Group
www.pepperl-fuchs.com

USA: +1 330 486 0002
pa-info@us.pepperl-fuchs.com

Germany: +49 621 776 2222
pa-info@de.pepperl-fuchs.com

Singapore: +65 6779 9091
pa-info@sg.pepperl-fuchs.com