



Superior Clamping and Gripping



Product data sheet

Force/torque sensor FT Omega85

Robust. Flexible. Precise.

6-axis force/torque sensor FT

Rigid 6-axis force/torque sensor for precision measuring in all six degrees of freedom

Field of application

Universally applicable in robotic applications such as haptics, medicine, grinding, testing, inserting, and research and development



Advantages – Your benefits

Many sizes with different measuring ranges

The sensor measures in all six degrees of freedom forces as well as moments

Rotation and translation of the coordinates system in all three directions in space

Integrated temperature compensation to ensure the defined measuring accuracy

Easy integration into the process due to easy interface compatibility

Robust design due to a higher overload range for a long service life

IP protection class IP60, 65, 68 available as an option



Sizes
Quantity: 17



Measuring range of
force
 $\pm 8 \dots 88000 \text{ N}$



Measuring range of
moment load
 $\pm 0.05 \dots 6000 \text{ Nm}$

Functional description

The strain gauges (DMS) of the 6-axis force/torque sensors measure the strain applied in all six degrees of freedom (F_x , F_y , F_z , M_x , M_y und M_z). The DMS signals are amplified in the sensor.

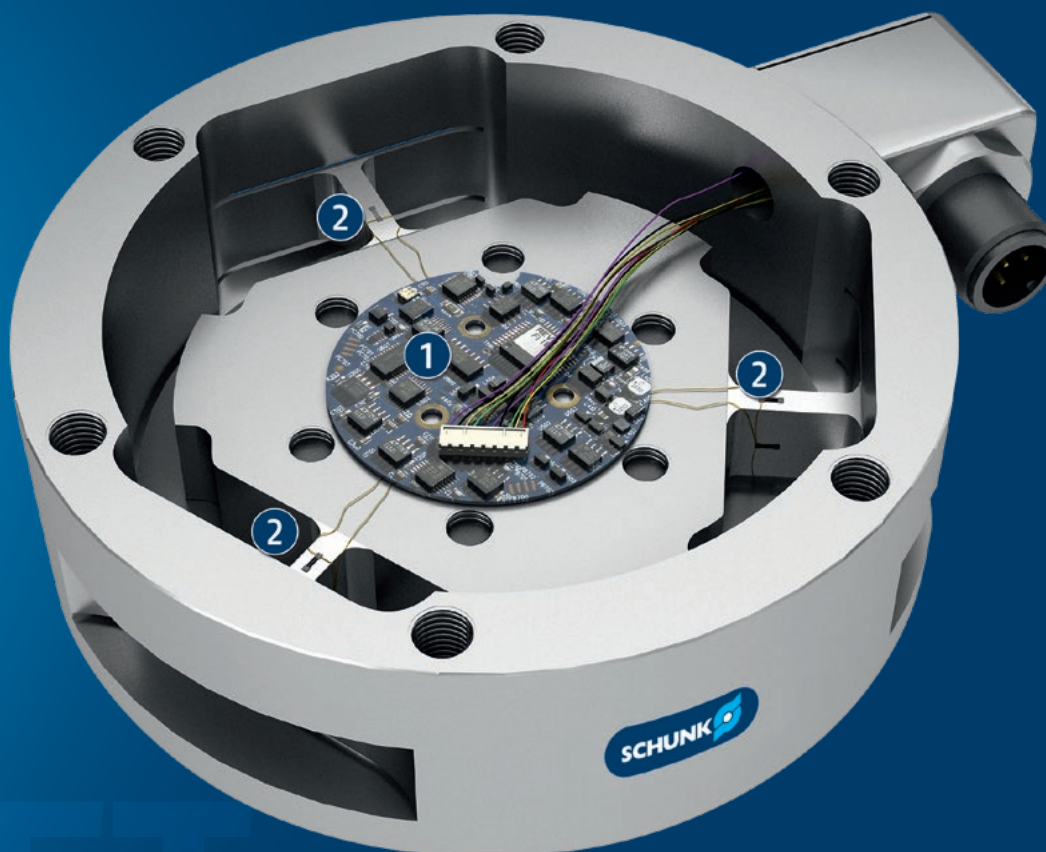

① **Electronics**
integration into housing means no interfering contours
(from size gamma)

② **Resistance strain gauges**
Silicon gauges provide a signal 75 times stronger than
conventional foil gages. This signal is amplified resulting
in near-zero noise distortion.

General notes about the series

Measuring accuracy: < 1% of the upper limit value of the measuring range at 22 °C

Splash water protection: IP60, 65, 68 available as an option

Housing: Aluminum and stainless steel

Warranty: 12 months

Harsh environmental conditions: Please note that use under harsh environmental conditions (e.g. in the coolant area, cast and grinding dust) can considerably reduce the service life of the units, and we will not take over any warranty. However, in many cases we can find a solution. Please contact us for assistance.

Handling weight: is the weight of the total load attached to the flange. When designing, the permissible forces and moments have to be paid attention to. Please note that exceeding the recommended handling weight will shorten the lifespan.

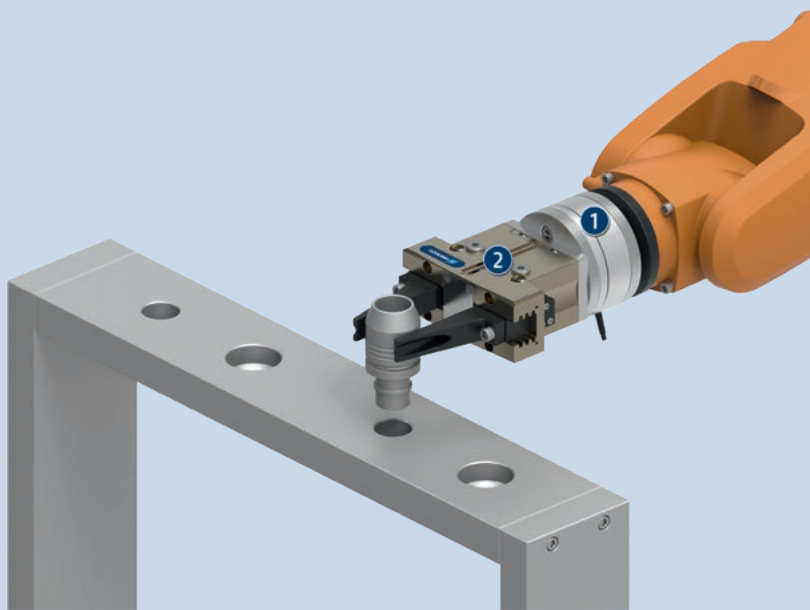

Application example

Gripping unit with force/torque sensor for quality control of piston diameters

① 6-axis force/torque sensor FT for insertion into the measuring station

② 2-finger parallel gripper PGN-plus-P for handling of workpieces

SCHUNK offers more ...

The following components make the product even more productive – the suitable addition for the highest functionality, flexibility, reliability, and controlled production.



EtherNet/IP-Version



DAQ version



Stand-alone version



EtherCAT version

① For more information on these products can be found on the following product pages or at schunk.com.

Options and special information

6-axis force/torque sensor: Silicon resistance strain gauges (DMS) measure the strain applied in all six degrees of freedom (F_x , F_y , F_z , M_x , M_y and M_z). The DMS signals are amplified in the sensor. Due to the size, the amplifier board for the Nano and Mini series is located in the power supply box (IFPS) instead of the sensor.

Sensor cables: The sensor cable of the Nano and Mini sensors are connected directly to the sensor. From size Gamma upwards, the sensor line can be connected to the sensor plug. The highly flexible sensor cable protects the sensor signals against electrical fields and mechanical loads.

General Information

The SCHUNK 6-axis force/torque sensors (FT sensor) measure six components of force and moment (F_x , F_y , F_z , M_x , M_y , M_z). The SCHUNK FT sensors use silicon strain gauges, which provide for excellent noise immunity. The following interfaces are available for all sizes: FTN (Ethernet, DeviceNet or CAN, optionally with PROFINET), FTE (EtherCAT), FTD (PCI, USB).

Characteristics

The SCHUNK FT sensors feature diverse high-performance functions:

- **Zero point offset:**
Offsets and/or rotates the FT reference system.
- **Demo program:**
Allows settings and measurement recording.
- **Set to zero:**
Provides a simple way to compensate the tool weight.
- **Threshold compensation:**
Generates an output code when an automatically specified threshold is exceeded (FTN and FTE).
- **Built-in temperature balancing:**
Ensures accuracy of the measured values over a large temperature range.
- **Overload:**
SCHUNK FT sensors are particularly sturdy and have a long service life. The safety factor can be up as high as 40 times the range of measurement, depending on the particular size.
- **More interference-resistant measurement signal:**
Silicon expansion measurement strips provide a signal that is 75 stronger than conventional foil measurement strips and reduces signal noise to almost zero.
- **IP protection class:**
SCHUNK FT sensors are optionally available in versions with IP60, IP65 or IP68 protection.

Accuracy

Accuracy is the difference between the applied load and the actual load measured. The maximum measuring inaccuracy as a percentage refers to the maximum value that can be measured with the sensor (see example below for Gamma SI-32-2.5). The reproducibility or repeat accuracy is the difference between the measured values when the same load is applied each time.

Example: Gamma SI-32-2.5

Name	Calibration	F_x	F_y	F_z	T_x	T_y	T_z
Gamma	SI-32-2.5	0.75 %	1.00 %	0.75 %	1.00 %	1.25 %	1.00 %

F_x max. range of measurement is 32 N, max. measurement inaccuracy is 0.24 N.

F_z max. range of measurement is 100 N, max. measurement inaccuracy is 0.75 N.

Resolution

The resolution is the smallest change in the load that represents a change in the output values of the measured forces and moments. The smaller the resolution of an FT sensor, the larger is the sensitivity of the sensor. This is important when the application requires a "tactile sense."

Technical data

Type	Evaluation	Output speed	Latencytime
FTN	via Ethernet, DeviceNet optionally with PROFINET Standard mode RDT mode	leer 7000 Hz 7000 Hz	leer 500 µs 288 µs
FTE	via EtherCAT	1000 Hz	up to 1 ms
FTD	via DAQ card (PCI)	16.67 kHz up to 41.67 kHz	1/output speed

Application in Practice

SCHUNK 6-axis force/torque sensors are already used in a variety of robot-controlled applications:

- **Joining processes:**
Joining or fitting workpieces using the robot.
- **Deburring, polishing, grinding:**
Optimal results due to constant pressure forces.
- **Force/moment feedback:**
Controlling manipulators (e.g. defusing bombs).
- **Medicine:**
Developing prosthetics and simulating operations.
- **Product tests:**
Haptic measurements for automotive parts and smart-phone displays.
- **Research and development:**
Due to the highly precise and reproducible measurement results, it is used in many universities and research institutes
- **Service robotics:**
Flexible and versatile due to the compact design.



The force/torque feedback between the robot and SCHUNK FT sensor allows a significantly increase in quality of the automated grinding of supply air chambers for fireplaces.

FTN – the All-rounder for your Interfaces

The FTN sensor is connected to the system via EtherNet/IP or DeviceNet (optional PROFINET). The web browser interface facilitates simple configuration and adjustment of the FTN sensor.

Product features

- Completely ODVA™ compliant EtherNet/IP interface (optionally available with PROFINET).
- The NetBox of the FTN system has the IP65 protection class.
- The NetBox is supplied with power using Ethernet (Power over Ethernet, PoE) or an external power supply (11 V to 24 V).
- Up to 16 sensor calibrations can be permanently stored in the system and selected by the user.

Scope of delivery: FT sensor, sensor cable, NetBox, optional RJ45 adapter



- 1 FT sensor
- 2 Sensor cables
- 3 NetBox
- 4 Optionally with RJ45 adapter

FTE – Ultra-fast communication standard

The FTE sensor is connected to the system using EtherCAT. The interface is available for all sensors of the Nano and Mini series as well as for selected IP versions of the Gamma, Delta and Omega series.

Product features

- Calibration with up to three measurement ranges possible
- Access to the measurement data via PDO or SPI bus communication
- Nano/Mini sizes: evaluation with ECATOEM or ECATBA
- Gamma/Delta/Omega sizes: electronics and status LED integrated into housing

Scope of delivery Nano/Mini: FT sensor with cable, ECATOEM or ECATBA

Scope of delivery Gamma/Delta/Omega: FT sensor with onboard electronics, optionally with cable (4-pin M12 to RJ45)



- 1 FT sensor with cable
- 2 Interface board ECATOEM
- 3 Interface box ECATBA
- 4 FT sensor with onboard electronics
- 5 RJ45 adapter (optional)

FT

Force/torque sensor

FTD – for simple Data Collection via PC

The FTD sensor is connected to the PC by means of a DAQ card. The six analog output signals from the sensor are converted to digital signals by means of the electronics in the DAQ card. Afterwards, the software (provided by the customer) uses the calibration matrix to graphically display the occurring forces and moments on the PC.

Product features

- Maximum possible output speed
- Numerous DAQ cards can be used
- Dual calibration possible

Scope of delivery: FT sensor, sensor cable, power supply box, optional with DAQ card (PCI or USB)



- 1 FT sensor with cable
- 2 Power supply box
- 3 Optional with DAQ card (PCI)
- 4 Optional with DAQ card (USB)
- 5 Cable for DAQ card

Selection scheme for 6-Axis force/torque sensors

1. Calculating the expected forces and moments

Generally, the moment load is the decisive variable in selecting a sensor. The tool weight and application process generate forces that can act on the sensor as moments. The moment is calculated from the applied force (static and dynamic) multiplied by the lever arm. The lever arm is the distance from the point of application of the force to the zero point of the sensor. The design must also take the forces and moments into account that can act upon the sensor outside of normal operation.

Example

The maximum expected force that will act upon the sensor is 98 N (10 kg). This force acts on the sensor from a distance of 25 cm. Therefore the moment is 24.5 Nm. The FT-Delta-SI-330-30 would be suitable for this application (range of measurement 330 N and 30 Nm).

2. Pre-selection of the sensor based on forces and moments

Use the table below for this.

3. Definition of the resolution

Check whether the resolution of the sensor matches your requirements. As a rule of thumb, the larger the range of measurement, the lower the resolution.

Quick overview FT

Description	Max. F_x, F_y	Max. F_z	Max. M_x, M_y, M_z	Weight	Diameter	Height
Leer	[±N]	[±N]	[±Nm]	[kg]	[mm]	[mm]
Nano17 Titanium	32	56.4	0.2	0.00907	17	14
Nano17	50	70	0.5	0.00907	17	14
Nano17 IP65/IP68	50	70	0.5	0.0408	20	22
Nano25	250	1000	6	0.0635	25	22
Nano25 IP65/IP68	250	1000	6	0.136	28	27
Nano43	36	36	0.5	0.0408	43	11
Mini40	80	240	4	0.0499	40	12
Mini40 IP64/IP68	80	240	4	0.272	53	21
Mini43LP	250	250	2	0.5	43	7.9
Mini45	580	1160	20	0.0907	45	16
Mini45 IP65/IP68	580	1160	20	0.39	58	25
Mini58	2800	6800	120	0.499	58	30
Mini58 IP60	2800	6800	120	0.522	82	36
Mini58 IP65/IP68	2800	6800	120	0.803	66	38
Mini85	1900	3800	80	0.635	85	30
Gamma	130	400	10	0.254	75	33
Gamma IP60	130	400	10	0.467	99	40
Gamma IP65	130	400	10	1.09	110	52
Gamma IP68	130	400	10	1.98	110	52
Delta	660	1980	60	0.912	94	33
Delta IP60	660	1980	60	1.81	120	47
Delta IP65	660	1980	60	1.77	130	52
Delta IP68	660	1980	60	2.63	100	52
Theta	2500	6250	400	4.99	150	61
Theta IP60	2500	6250	400	8.62	190	74
Theta IP65/80	2500	6250	400	9	160	75
Omega85	1900	3800	80	0.658	85	34
Omega85 IP65/IP68	1900	3800	80	1.91	93	39
Omega160	2500	6250	400	2.72	160	56
Omega160 IP60	2500	6250	400	7.67	190	58
Omega160 IP65	2500	6250	400	7.26	170	66
Omega191	7200	18000	1400	9.41	190	64
Omega191 IP60	7200	18000	1400	14.1	238	73.7
Omega191 IP65/IP68	7200	18000	1400	13.2	204	74.8
Omega250 IP60	16000	32000	2000	31.8	290	95
Omega250 IP65	16000	32000	2000	31.8	290	95
Omega331	40000	88000	6000	47	330	110

FT Omega85

Force/torque sensor

Dimensions and maximum loads

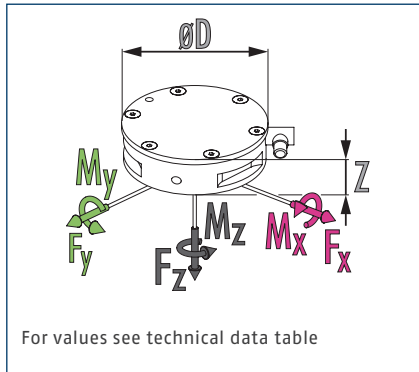

ⓘ All forces and torques acting on the sensor must be within the specified measurement range. Exceeding the measurement range will reduce the maximum number of load cycles and may lead to damage of the sensor. Please contact us if your application exceeds the measurement range.

Technical data FTN

Description		FTN-Omega85 SI-475-20	FTN-Omega85 SI-950-40	FTN-Omega85 SI-1900-80
evaluation via		EtherNet/IP	EtherNet/IP	EtherNet/IP
Weight	[kg]	0.658	0.658	0.658
Calibration		SI-475-20	SI-950-40	SI-1900-80
Measuring range Fx, Fy	[N]	±475	±950	±1900
Measuring range Fz	[N]	±950	±1900	±3800
Measuring range Mx, My	[Nm]	±20	±40	±80
Measuring range Mz	[Nm]	±20	±40	±80
Overload Fx, Fy	[N]	±13000	±13000	±13000
Overload Fz	[N]	±27000	±27000	±27000
Overload Mx, My	[Nm]	±500	±500	±500
Overload Mz	[Nm]	±610	±610	±610
Resonant Frequency Fx, Fy, Mz	[Hz]	2100	2100	2100
Resonant Frequency Fz, Mx, My	[Hz]	3000	3000	3000
Resolution Fx, Fy	[N]	0.075	0.145	0.285
Resolution Fz	[N]	0.11	0.215	0.43
Resolution Mx, My	[Nm]	0.003	0.007	0.015
Resolution Mz	[Nm]	0.002	0.005	0.009
Dimensions Ø D x Z	[mm]	85 x 33.4	85 x 33.4	85 x 33.4

Technical data deviations for FTD

Description		FTD-Omega85 SI-475-20	FTD-Omega85 SI-950-40	FTD-Omega85 SI-1900-80
evaluation via		DAQ	DAQ	DAQ

ⓘ Please note that the dimensions, dead weight and resonance frequency of the IP protection versions differ from the basic version.

Main view

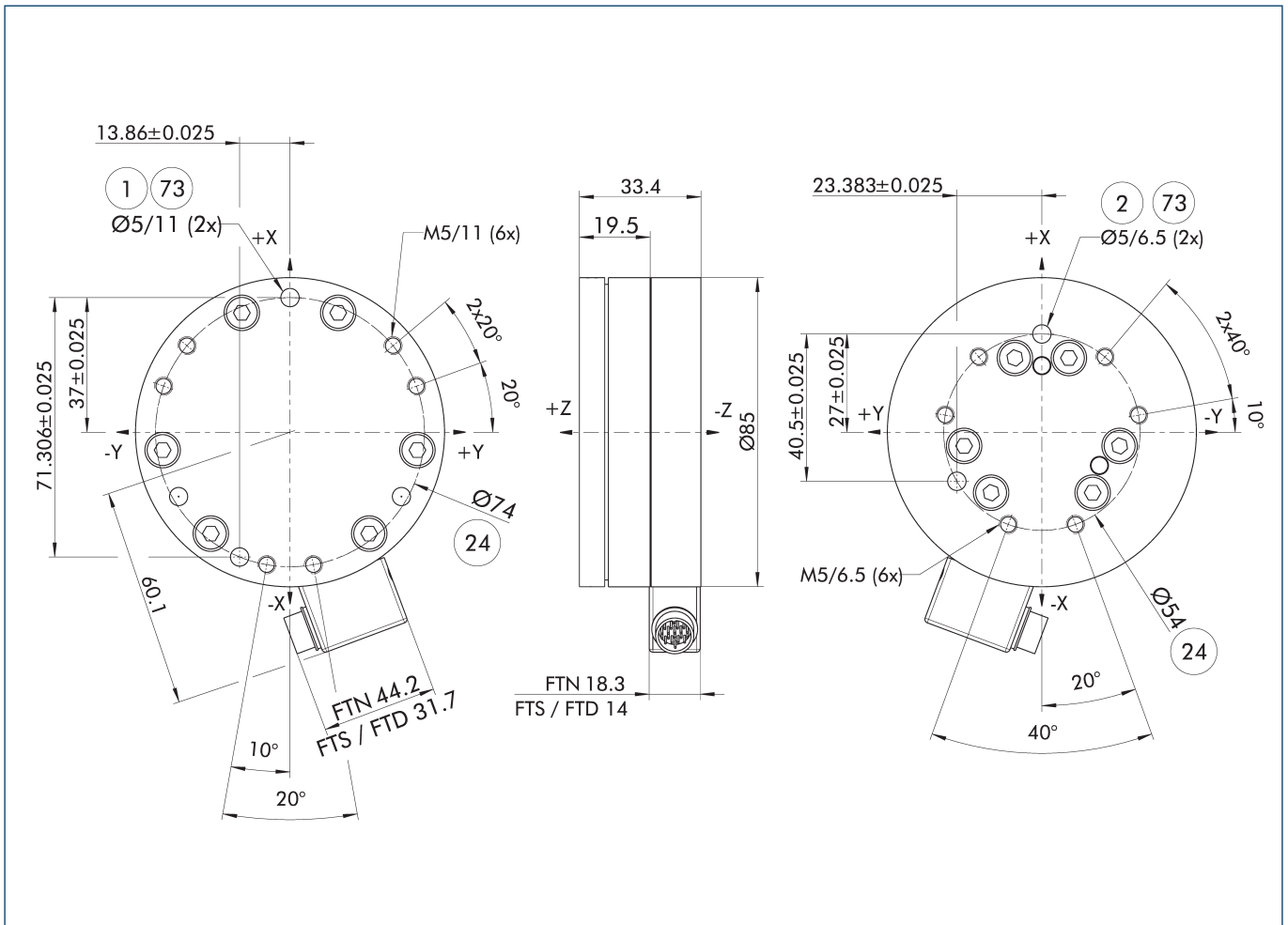

The main view shows the unit in its basic version.

- ① Robot-side connection
- ② Tool-side connection

- ②④ Bolt circle
- ⑦③ Fit for centering pins

FT Omega85

Force/torque sensor

Main view IP65/IP68

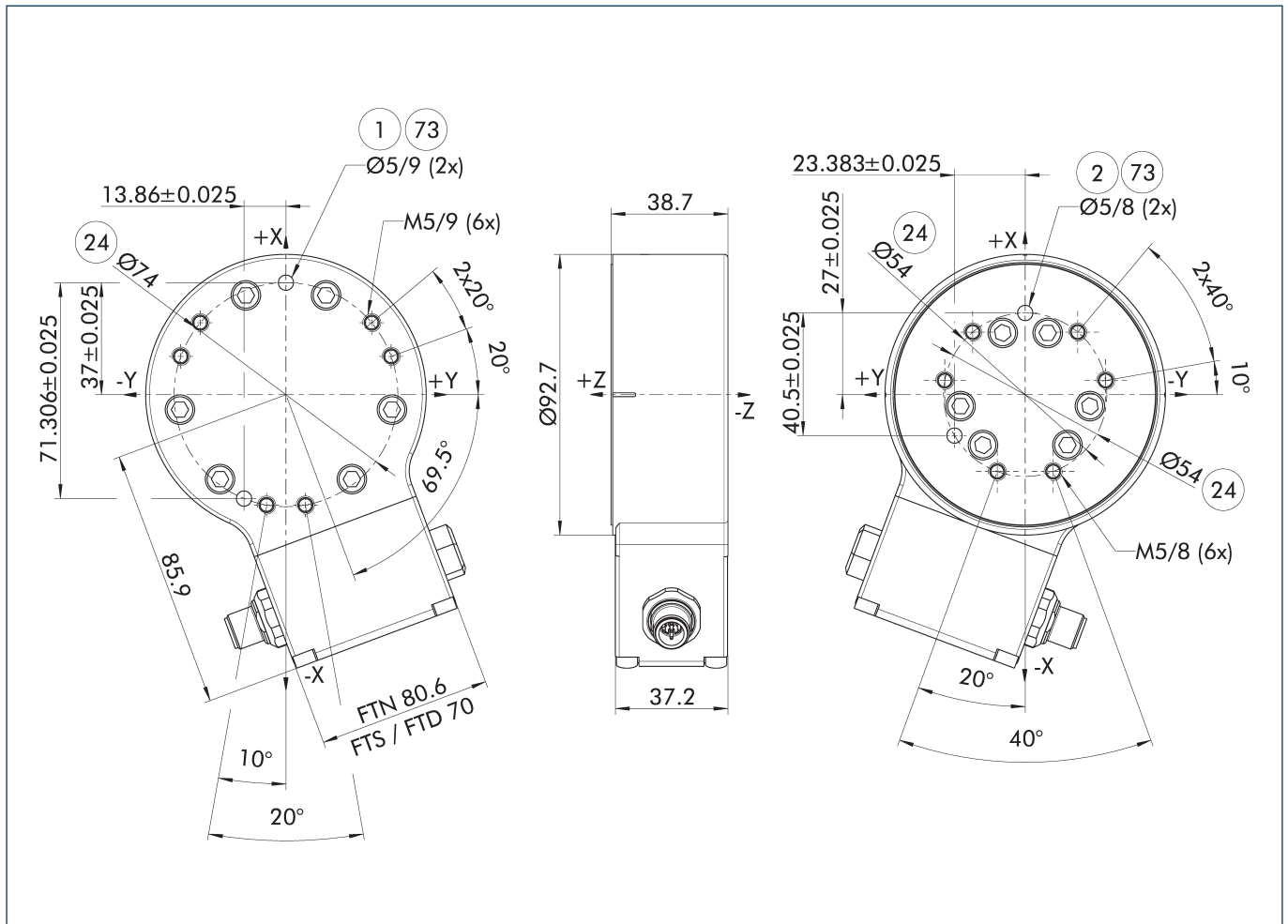

The main view shows the product with IP protection.

- ① Robot-side connection
- ② Tool-side connection

- ②④ Bolt circle
- ⑦③ Fit for centering pins



SCHUNK GmbH & Co. KG
Spann- und Greiftechnik

Bahnhofstr. 106 - 134
D-74348 Lauffen/Neckar
Tel. +49-7133-103-0
Fax +49-7133-103-2399
info@de.schunk.com
schunk.com

Folgen Sie uns | *Follow us*

