



Hand in hand for tomorrow



## Product data sheet

Force/torque sensor FTS 160

# FTS

Force/torque sensor

## Precise. Compact. High resolution.

# 6-axis force/torque sensor FTS

For high-precision measurement in the degrees of freedom Fxyz and Mxyz

## Field of application

6-axis force/torque sensors are used to carry out precise measurements of forces and moments in all three spatial directions. They are used in robotics to monitor and control the interaction between robots and their environment, as well as in industrial automation for quality control and process monitoring. They are also used in biomechanics and medical technology to analyze motion sequences and optimize prosthetic systems.



## Advantages – Your benefits

**Maximum precision** The strain gauges of the 6-axis force/torque sensor record the mechanical deformation of the sensor body and convert this into high-precision signals in all six degrees of freedom (Fx, Fy, Fz, Mx, My, Mz)

**Reliable protection** Suitable for use in demanding environments thanks to protection class IP67

**Seamless integration** The Interface Box with EtherNet/IP, EtherCAT and PROFINET interfaces enables simple and flexible connection to customer network topologies

**Intuitive commissioning** The SCHUNK Control Center simplifies commissioning with a user-friendly interface and creates synergies with other SCHUNK products

**Visual condition monitoring** Integrated LEDs for power, communication, and sensor status facilitate status monitoring

**Robust base body** The high rigidity ensures high measuring accuracy and durability, even in dynamic applications



Sizes  
Quantity: 7



Range of force  
measurement Fx/Fy  
±125 .. 5000 N



Range of force  
measurement Fz  
±300 .. 12500 N



Measuring range of  
moment load  
±4.5 .. 700 Nm

## Functional description

The strain gauges (DMS) of the 6-axis force/torque sensor measure the loads applied in all six degrees of freedom ( $F_x$ ,  $F_y$ ,  $F_z$ ,  $M_x$ ,  $M_y$ , and  $M_z$ ). The DMS signals are amplified in the sensor.

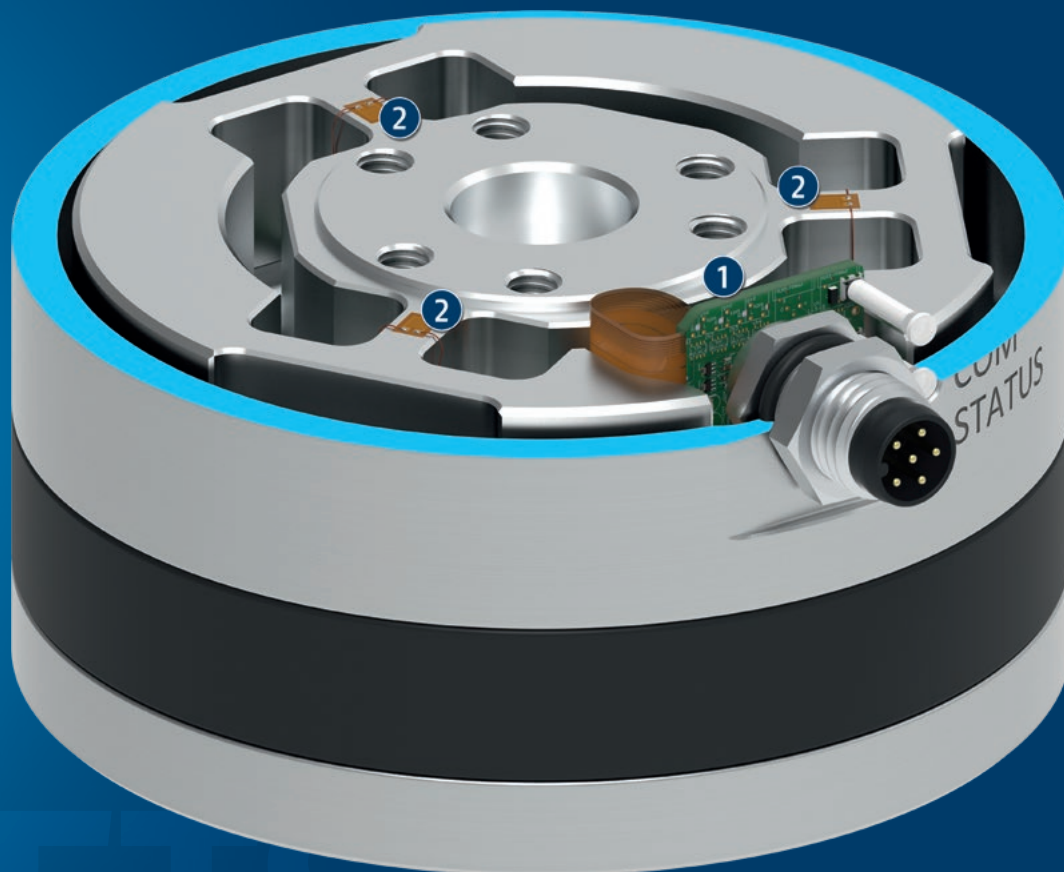

① **Electronics**  
no interfering contour, as integrated in the housing

② **Foil strain gauges**  
in combination with low-noise signal processing, they ensure high resolution and signal quality.

# FTS

Force/torque sensor

## Detailed functional description

### Standard adapter plates

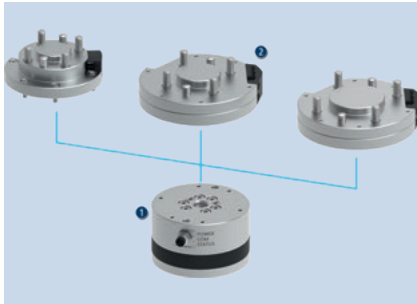

We offer 3 suitable standard adapter plates for suitable ISO 9409 interfaces for each sensor size.

- 1 6-axis force/torque sensor FTS
- 2 Adapter plates as per DIN ISO 9409

### Connectivity



The large number of interfaces offers an excellent opportunity for flexible integration into the customer's control systems.

### Commissioning app in the SCHUNK control center



The SCHUNK Control Center ensures simple commissioning, parameterization, and diagnosis of the FTS sensor system. Users can visualize and save measurement data directly. The sensor coordinate system can be moved to the desired tool center point and load limits can also be defined. Moreover, the functions include network configuration, firmware updates, parameter adjustments, and backups as well as comprehensive diagnostic options. The app is compatible with Windows and can be downloaded at [schunk.com/downloads-software](http://schunk.com/downloads-software).

### Interface Box FTS IFB



The Interface Box is optionally available in IP 67. Depending on the firmware variant, the Interface Box can communicate via one of the following interfaces: PROFINET, EtherCAT, EtherNet/IP™, Ethernet (TCP/UDP).

- 1 Interface Box FTS IFB
- 2 Interface box FTS IFB-IP67



## General notes about the series

**Measuring accuracy:** < 1% of the upper limit value of the measuring range at 22 °C

**Splash water protection:** IP67 as standard

**Housing:** Aluminum and stainless steel

**Warranty:** 24 months

**Harsh environmental conditions:** Please note that use under harsh environmental conditions (e.g. in the coolant area, cast and grinding dust) can considerably reduce the service life of the units, and we will not take over any warranty. However, in many cases we can find a solution. Please contact us for assistance.

**Handling weight:** is the weight of the total load attached to the flange. When designing, the permissible forces and moments have to be paid attention to. Please note that exceeding the recommended handling weight will shorten the lifespan.



## Application example

In haptics measurement, the FTS 6-axis force/torque sensor is used to analyze the interaction between an object and its environment. The sensor is either integrated directly into a measuring device or used in conjunction with a robot arm, which ensures precise movements and pressure exertion.

- ❶ 6-axis force/torque sensor FTS
- ❷ Universal gripper EGU

## SCHUNK offers more ...

The following components make the product even more productive – the suitable addition for the highest functionality, flexibility, reliability, and controlled production.



Adapter plate on ISO flange



Sensor cables



Interface Box FTS IFB

① For more information on these products can be found on the following product pages or at [schunk.com](http://schunk.com).



### Display deviation & crosstalk

The display deviation or the max. relative deviation of the displayed measured value describes the deviation of the displayed force or the displayed moment from the true load applied. It mainly consists of linearity errors and cross-talk between the individual channels. SCHUNK FTS sensors achieve a max. relative deviation of  $\leq 1.0\%$  in relation to the measuring range end value (full-scale, f. s.).

### Display resolution & saturation

The resolution is the smallest change in the load that represents a change in the output values of the measured forces and moments. The smaller the resolution of an FTS sensor, the greater the sensitivity of the sensor. This is important when the application requires a "tactile sense." The resolution of the sensor depends on the ambient conditions during the measurement, and in particular on the selected sampling rate and filtering.

	F <sub>x</sub>	F <sub>y</sub>	F <sub>z</sub>	M <sub>x</sub>	M <sub>y</sub>	M <sub>z</sub>
relative deviation	<1.0%f.s.	<1.0%f.s.	<1.0%f.s.	<1.0%f.s.	<1.0%f.s.	<1.0%f.s.

## Ordering example

	FTS	056	-	600	-	11
<b>Description</b>	FTS					
<b>O.D.-Diameter</b>	047 = $\emptyset$ 47 mm 056 = $\emptyset$ 56 mm 070 = $\emptyset$ 70 mm 085 = $\emptyset$ 85 mm 105 = $\emptyset$ 105 mm 125 = $\emptyset$ 125 mm 160 = $\emptyset$ 160 mm					
<b>Measuring range Fz</b>	300 = 300 N 600 = 600 N 1200 = 1200 N 2400 = 2400 N 4800 = 4800 N 7800 = 7800 N 12500 = 12500 N					
<b>Measuring range Mx, My, Mz</b>	4 = 4 Nm 11 = 11 Nm 28 = 28 Nm 70 = 70 Nm 175 = 175 Nm 350 = 350 Nm 700 = 700 Nm					



# FTS 160

Force/torque sensor

## Dimensions and maximum loads

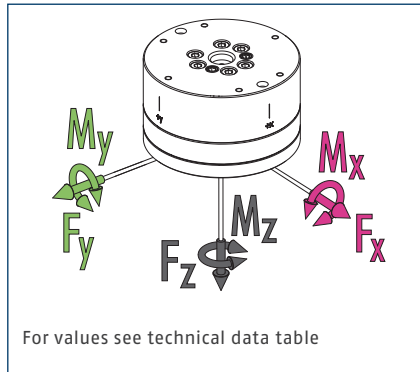

- ⓘ All forces and torques acting on the sensor must be within the specified measurement range. Exceeding the measurement range will reduce the maximum number of load cycles and may lead to damage of the sensor. Please contact us if your application exceeds the measurement range.

## Technical data

Description		FTS 160-12500-700
ID		1598251
Weight	[kg]	5.1
IP protection class		67
Measuring range Fx, Fy	[N]	±5000
Measuring range Fz	[N]	±12500
Measuring range Mx, My	[Nm]	±700
Measuring range Mz	[Nm]	±700
Resolution Fx, Fy	[N]	0.25
Resolution Fz	[N]	0.5
Resolution Mx, My	[Nm]	0.028
Resolution Mz	[Nm]	0.021
Relative display deviation in relation to the measuring range		<1,0 %-fs
max. display deviation Fx, Fy	[N]	50
max. display deviation Fz	[N]	125
max. display deviation Mx, My, Mz	[Nm]	7
max. sampling rate	[Hz]	1000
Max. output rate (UDP)	[Hz]	2000
Information on accessories		In addition to the FTS sensor, a connection cable and interface box are required

Main view

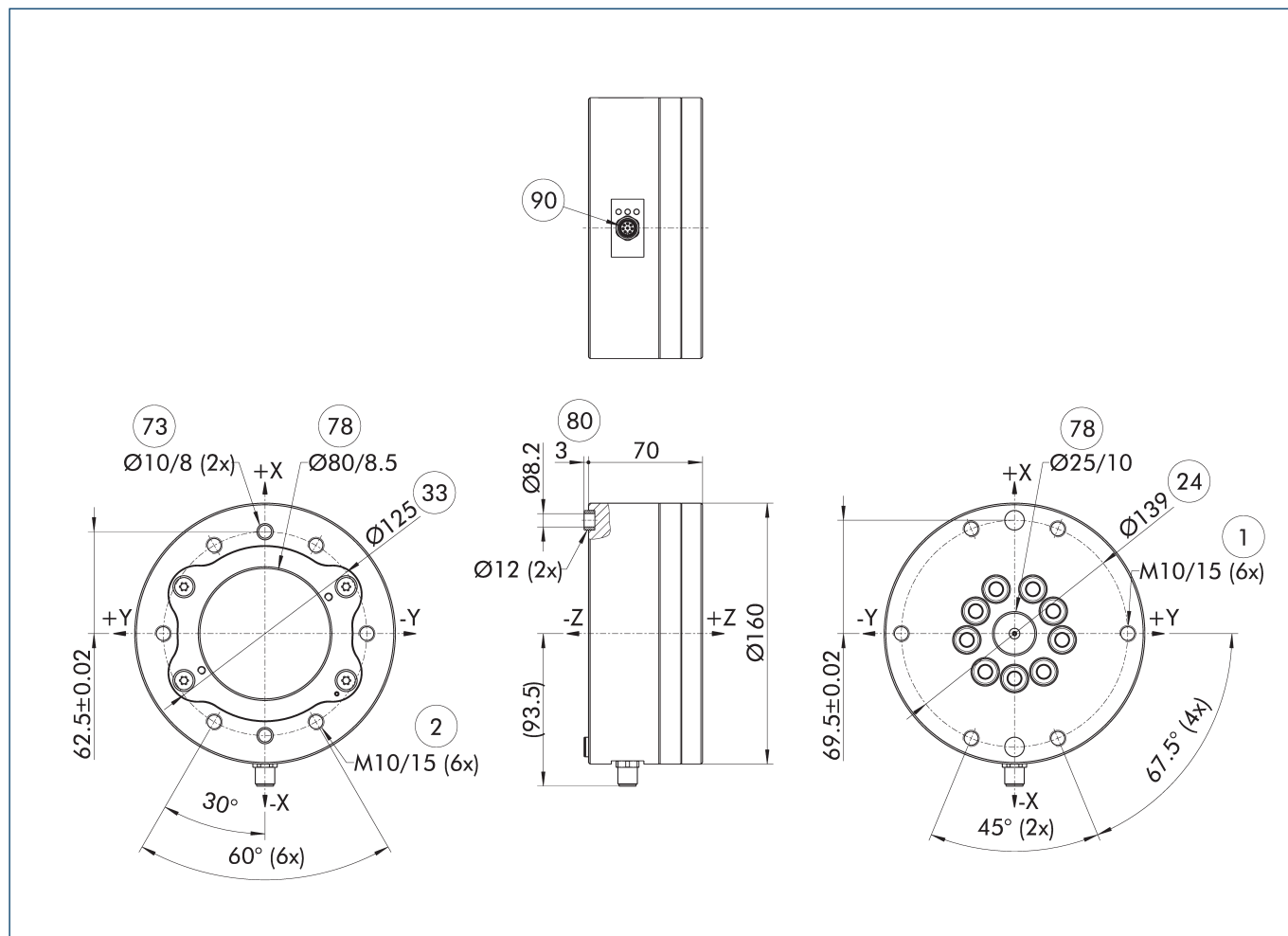

The main view shows the unit in its basic version.

- ① Robot-side connection
- ② Tool-side connection
- ④ Bolt circle
- ③③ DIN ISO-9409 bolt circle
- ⑦③ Fit for centering pins
- ⑦⑧ Fit for centering
- ⑧① Depth of the centering sleeve hole in the counter part
- ⑨① M12 socket, A-coded, 8-pin

Sensor system

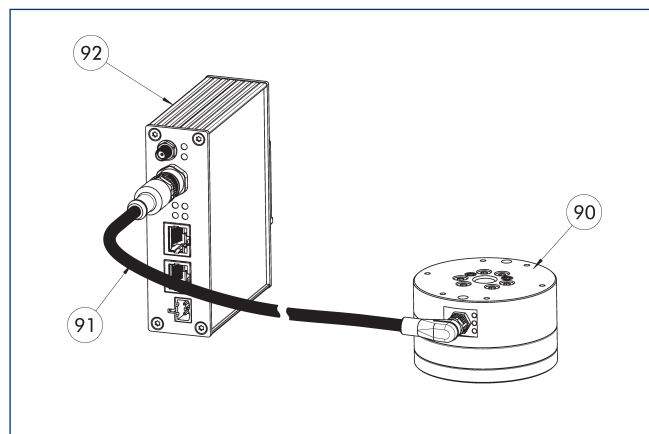

- ⑨① 6-axis force/torque sensor FTS
- ⑨② Interface Box FTS IFB or Interface Box FTS IFB IP 67
- ⑨① Sensor cables

# FTS 160

Force/torque sensor

## Sensor cables

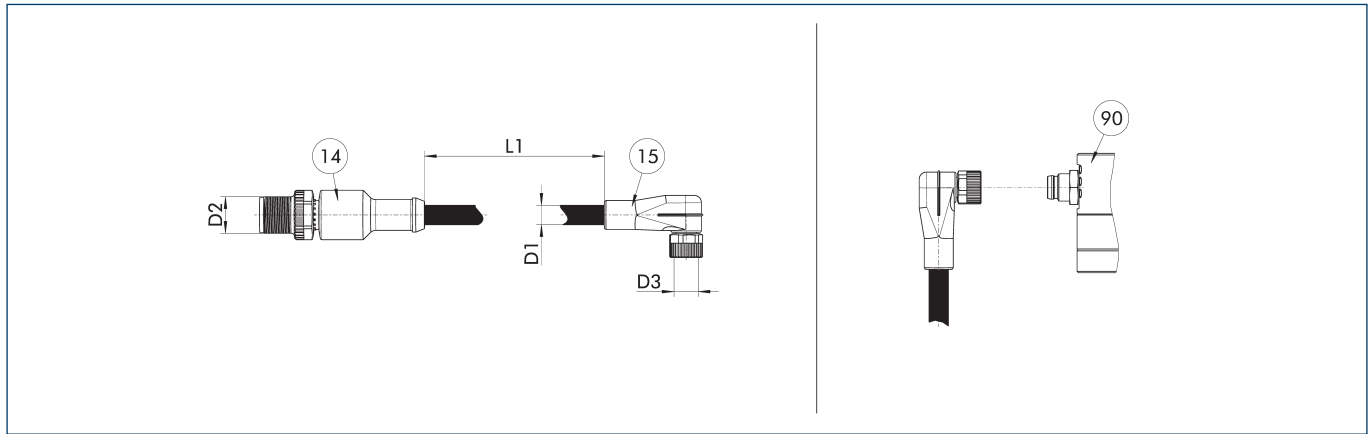

Sensor cable that connects the FTS sensor to the Interface Box.

- 14 Connector
- 15 Socket

90 6-axis force/torque sensor FTS

Description	ID	Cable length L1	Cable diameter D1	Connection on control cabinet side D2	Connection on sensor side D3
		[m]	[mm]		
<b>Communication cables</b>					
FTS C-M12-M12-10	1608057	10	6	M12	M12
FTS C-M12-M12-15	1608059	15	6	M12	M12
FTS C-M12-M12-2	1620906	2	6	M12	M12
FTS C-M12-M12-30	1608071	30	6	M12	M12
FTS C-M12-M12-5	1608055	5	6	M12	M12

## Interface Box FTS IFB

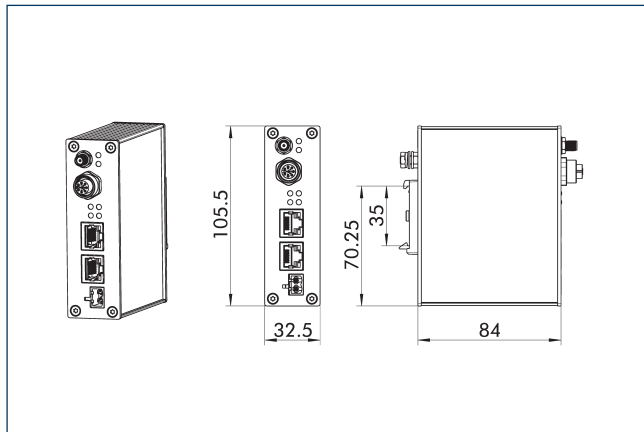

Description	ID	Communication interface
<b>Interface box</b>		
FTS IFB-EC	1603604	EtherCAT
FTS IFB-EI	1603602	EtherNet/IP
FTS IFB-EN	1651726	Ethernet (TCP/UDP)
FTS IFB-PN	1603600	PROFINET

Interface box FTS IFB-IP67

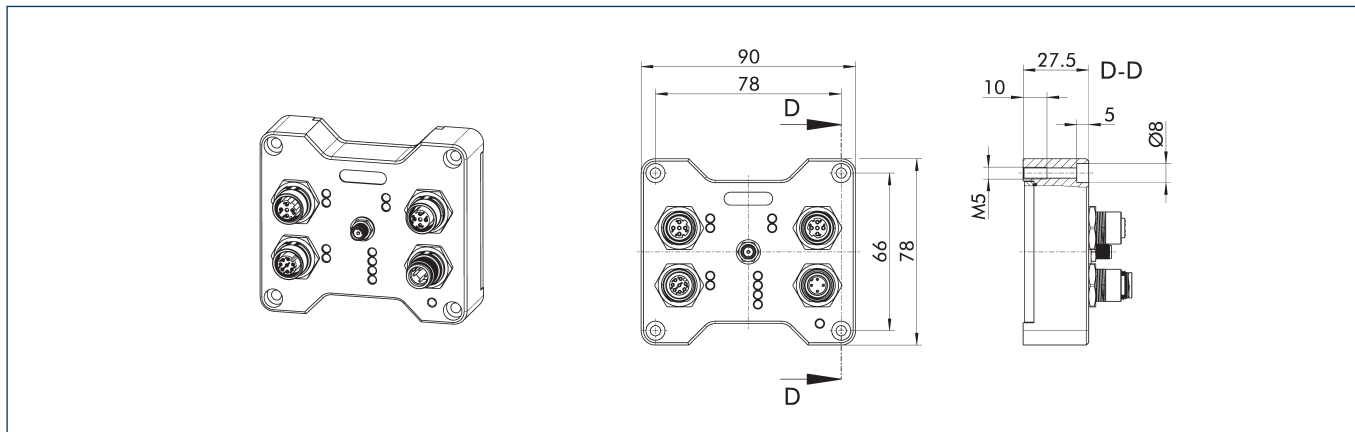

Description	ID	Communication interface	IP protection class	Cable length [m]
<b>Interface box</b>				
FTS IFB-EC-IP67	1603606	EtherCAT	67	
FTS IFB-EI-IP67	1603603	EtherNet/IP	67	
FTS IFB-EN-IP67	1651748	Ethernet (TCP/UDP)	67	
FTS IFB-PN-IP67	1603601	PROFINET	67	
<b>EtherCAT connection cable star distributor M12 D-coded socket, straight; on M8 A-coded connector, straight</b>				
KA GGN12D04-08A04-ET-00020-A	1521990			0.2
<b>Communication cable suitable for drag chain M12 connector, straight – to M12 connector, straight</b>				
KA GGN12D04-12D04-ET-00500-A	1505114			5
KA GGN12D04-12D04-ET-01000-A	1505119			10
<b>Communication cable suitable for drag chain M12 connector, straight – to RJ45 connector, straight</b>				
KA GGN12D04-RJ45-ET-00200-A	1511256			2
KA GGN12D04-RJ45-ET-00500-A	1354681			5
KA GGN12D04-RJ45-ET-01000-A	1505143			10
<b>Communication cable suitable for drag chain M12 connector, angled – to M12 connector, straight</b>				
KA WGN12D04-12D04-ET-00500-A	1354661			5
KA WGN12D04-12D04-ET-01000-A	1505141			10
<b>Communication cable suitable for drag chain M12 connector, angled – to RJ45 connector, straight</b>				
KA WGN12D04-RJ45-ET-00500-A	1354688			5
KA WGN12D04-RJ45-ET-01000-A	1505142			10
<b>Communication cable suitable for torsion-resistant M12 connector, straight – to M12 connector, straight</b>				
KAR GGN12D04-12D04-ET-00500-A	1505146			5
KAR GGN12D04-12D04-ET-01000-A	1505147			10
<b>Communication cable suitable for torsion-resistant M12 connector, straight – to RJ45 connector, straight</b>				
KAR GGN12D04-RJ45-ET-00500-A	1354677			5
KAR GGN12D04-RJ45-ET-01000-A	1505160			10
<b>Communication cable suitable for torsion-resistant M12 connector, angled – to M12 connector, straight</b>				
KAR WGN12D04-12D04-ET-00500-A	1354674			5
KAR WGN12D04-12D04-ET-01000-A	1505148			10
<b>Communication cable suitable for torsion-resistant M12 connector, angled – to RJ45 connector, straight</b>				
KAR WGN12D04-RJ45-ET-00500-A	1354692			5
KAR WGN12D04-RJ45-ET-01000-A	1505149			10
<b>Power cable – cable track compatible</b>				
KA GLN1204-LK-00200-K	0349270			2
KA GLN1204-LK-00500-K	0349271			5
KA GLN1204-LK-01000-K	0349272			10
KA GLN1204-LK-01500-K	0349273			15

# FTS 160

Force/torque sensor

## Adapter plate A-IS0100/FTS160

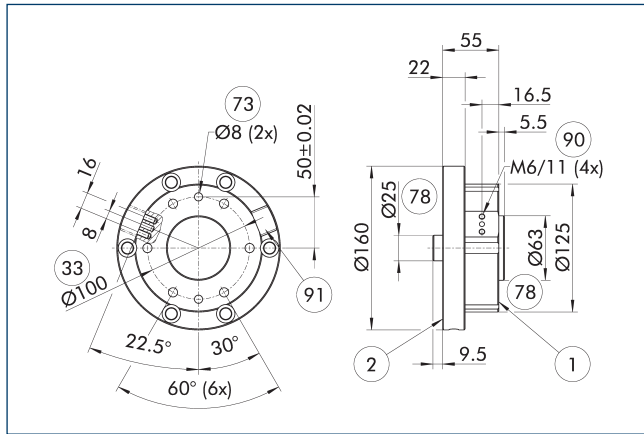

- ① Robot-side connection
- ② Tool-side connection
- ③③ DIN ISO-9409 bolt circle
- ⑦③ Fit for centering pins
- ⑦⑧ Fit for centering
- ⑨⑦⑧ mounting option provided by the customer
- ⑨① Strain relief

Description	ID	
Adapter plate		
A-IS0100/FTS160	1610503	

## Adapter plate A-IS0125/FTS160

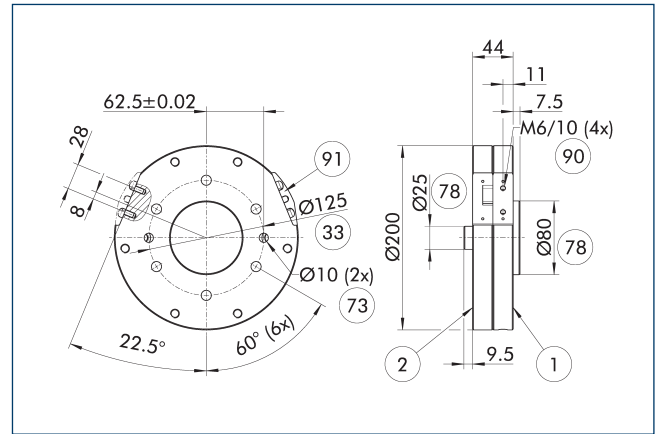

- ① Robot-side connection
- ② Tool-side connection
- ③③ DIN ISO-9409 bolt circle
- ⑦③ Fit for centering pins
- ⑦⑧ Fit for centering
- ⑨⑦⑧ mounting option provided by the customer
- ⑨① Strain relief

Description	ID	
Adapter plate		
A-IS0125/FTS160	1610504	

## Adapter plate A-IS0160/FTS160

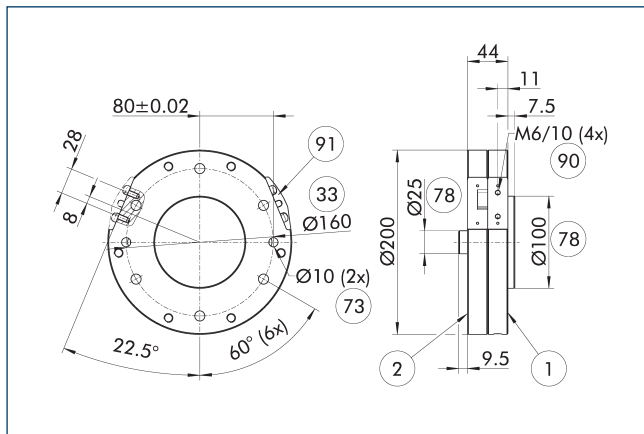

- ① Robot-side connection
- ② Tool-side connection
- ③③ DIN ISO-9409 bolt circle
- ⑦③ Fit for centering pins
- ⑦⑧ Fit for centering
- ⑨⑦⑧ mounting option provided by the customer
- ⑨① Strain relief

Description	ID	
Adapter plate		
A-IS0160/FTS160	1610505	





**SCHUNK SE & Co. KG**

**Spanntechnik**

**Greiftechnik**

**Automatisierungstechnik**

Bahnhofstr. 106 - 134

D-74348 Lauffen/Neckar

Tel. +49-7133-103-0

Fax +49-7133-103-2399

info@de.schunk.com

schunk.com

Folgen Sie uns | *Follow us*

