

**X-S09-A-W17-3M-OP**

**Feature**

- ★ X-S09-A-W17-3M adopts high-precision resistance strain principle
- ★ Supports force measurement in the range of 0-50kg.
- ★ S-type structural design, compression and tension, easy to install and flexible.
- ★ Small size, beautiful appearance

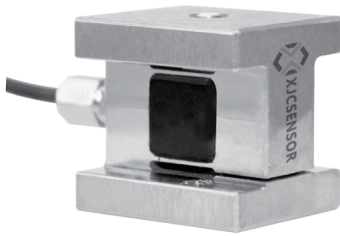

Dimension and capacity can be customized by request.

**Technical specifications**

Capacity ( Optional )	5kg, 10kg, 20kg, 50kg	Material	Stainless steel Aluminum alloy
Nonlinearity	≤ 0.05% F.S.	Rated output	2.0±0.2mV/V
Recommended excitation	5-10VDC	Maximum excitation	10V DC
Protection class	IP54	Compensated temp range	-10 ~ 40 °C
Hysteresis	≤ 0.05% F.S.	Operating temp range	-20 ~ 80 °C
Repeatability	≤ 0.05% F.S.	Insulation	≥ 5000MΩ / 100VDC
Input impedance	350 ± 10 Ω	Output impedance	350±10Ω
Creep (30min)	≤ 0.05% F.S.	Temp effect on output	≤ 0.2% F.S. / 10°C
Zero balance	± 2% F.S.	Temp effect on zero	≤ 0.2% F.S. / 10°C
Safe load limit	150%F.S.	Ultimate load limit	200%F.S.
Cable size	∅2x4m	Fatigue life	Full scale more than 1 million times
Cable connection	Ex + : Red; Ex - : Black; Sig + : Green; Sig - : White		

**Load direction**

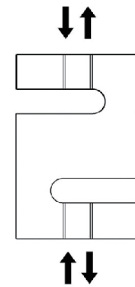

**Wiring code**

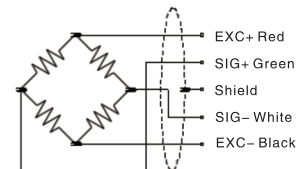

**Dimensional Drawings (mm)**

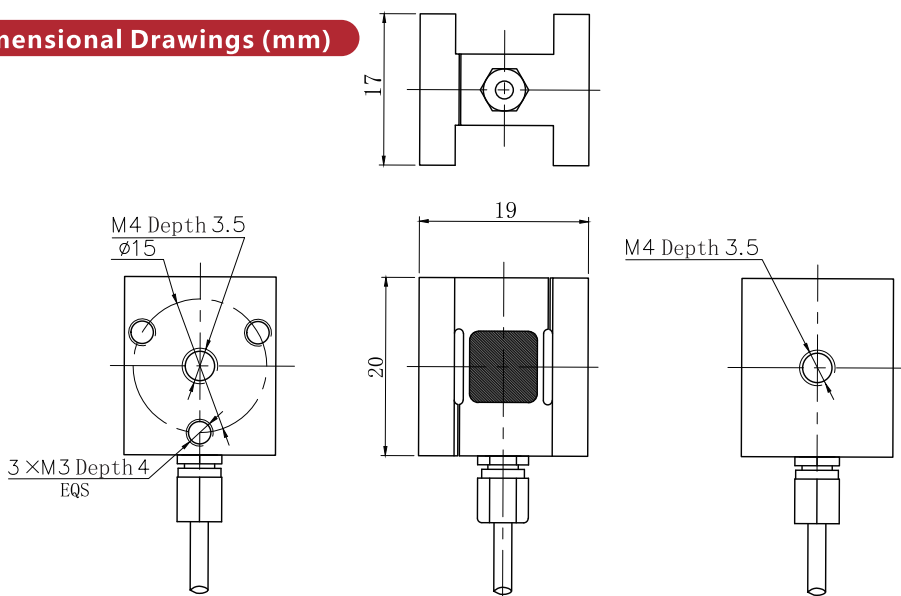

**Applications**

Automotive, medical, robot, electronic, mechanical equipment, automation equipment, etc.

Force measurement in small space installation, such as feeling tester for keyboard switch, compression force measurement for hot and cold lamination machine.