

● Characteristics



- Input:	pos. relative pressure (hydrostatic pressure)
- Analog output:	4...20 mA and 0...10 V
- Voltage supply:	24 VDC +/-20%
- Combined error:	±1% FS
- Casing:	Aluminum/plastic/plastic with EMC-coating
- Indication:	LCD-display
- Pressure connection:	for 6 mm plastic pipe
- Interface:	CANopen / Profibus (options)
- Protection class:	IP65
- Data output:	interface RS232
- Volume calculation:	20 calibration points for linearization

● Advantages in Comparison to other Measuring Methods

- No contact between sensor and medium (disadvantage with diving probe)
- No extensive mechanical construction (a pressure sensor needs a connection below the tank)
- Cost-effective solution (in difference to the use of radar engineering)
- Foaming has no influence (problem with ultrasonics)
- Easy mounting
- Reliable function

● Technical Data

Input

Kind of pressure:	positive relative pressure (hydrostatic pressure)
Pressure sensor:	Standard: 0...1000 mbar / 0...10 m water column
Option:	see pressure table on page 3
Burst pressure:	Standard: 3 bar
Option:	see pressure table on page 3

Output

Analog:	0...10 V and 4...20 mA
Current:	working resistance <500 Ω
Voltage:	load resistor >10 kΩ
Interface:	RS232 (option: CANopen / Profibus)

● Applications

For use in all ranges where conventional level measuring is not possible or too expensive. Range of application: Purification plants, pump houses, well buildings, chemical industry, special vehicle construction (tanks for water and fuel), food manufacturing industry.



● Technical Data (Continued)

Indication

Display: multifunton indicator for current values / switch points / diagnostic values
 Function: 4 keys for programming

Adjustment

Settings: 4 keys on display unit
 Tare: key on front or externally
 Volume calculation: 20 calibration points for linearization

Accuracy

Resolution: 12 bit (pressure sensor)
 Combined error: $\pm 1\%$ FS
 TC: < 50 ppm/K

Power Supply

Voltage: 24 VDC, $\pm 20\%$
 Power consumption: maximum 5 W
 Residual ripple: 200 mV

Environmental Conditions

Operating temperature: $-10 \dots +60^\circ\text{C}$
 Storage temperature: $-20 \dots +70^\circ\text{C}$

Mechanics

Casing aluminum:	Type:	aluCase AC 092 with clip-on design covers
	Dimensions:	160 x 90 x 60 mm
Casing plastics:	Material:	die-cast aluminum
	Mounting:	covered screw channels
	Color:	RAL 9006 (aluminum white)
	Weight:	approx. 1,1 kg (with options)
	Cable entry:	2 screwed cable glands M20x1,5
	Type:	U-CASE 2
	Dimensions:	162,2 x 92,2 (101,1) x 60,2 mm
	Material:	ASA 757G Luran S
	Flammability:	UL94 HB
	Mounting:	4 mounting holes
Protection class:	Colour:	black
	Weight:	approx. 0,7 kg (with options)
	Cable entry:	2 screwed cable glands M20x1,5
	Protective insulation:	according VDE100
	Connection:	IP65
	Connection:	plug-in terminal strip, lockable, up to maximum 2,5 mm ²
	Pressure connection:	for tube 6 mm O/D (nylon, PA, PUR, Hytrel), for sealing: O-ring (silicone free)
	Airing:	pressure compensation part (PA6)

● Dimensions (in mm)

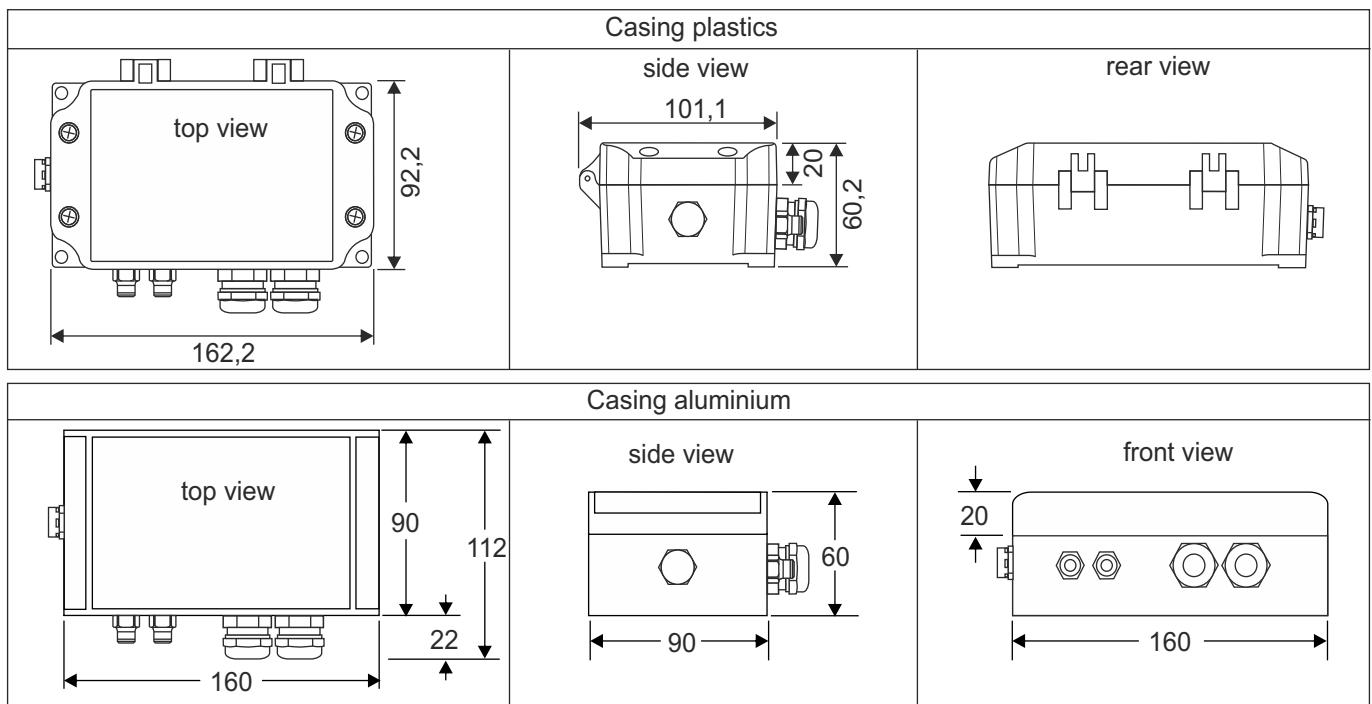

● Electrical Connection

+	⊥	+	+	⊥			⊥	+	+	
1	2	3	4	5	6	7	8	9	10	plug-in terminal strip
voltage supply 24 V DC		analog output (0)4...20 mA 0...10 V						external tare		

● Application Example

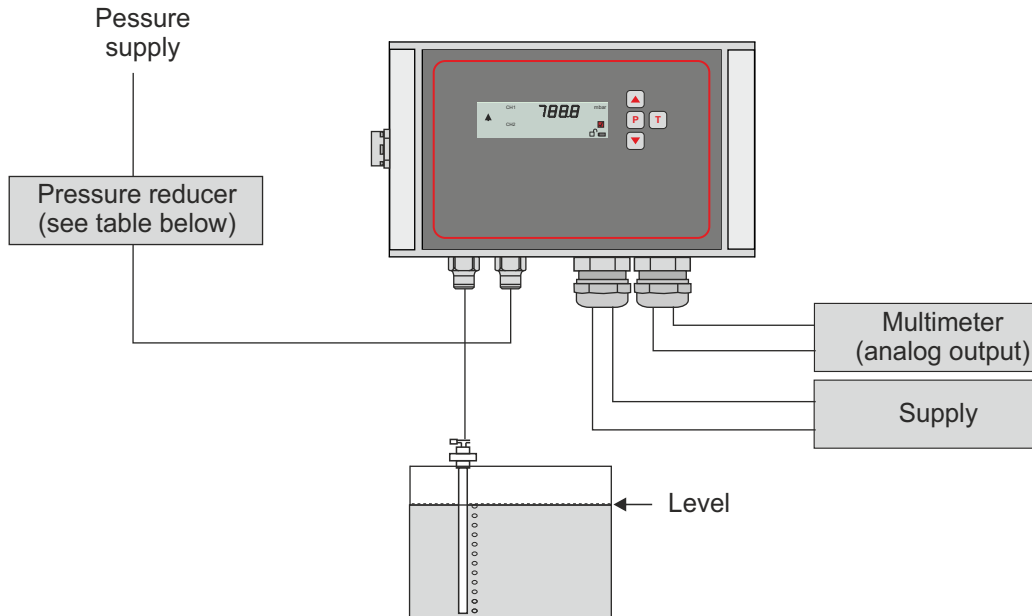

Pressure Table

Nominal pressure	50 mbar	100 mbar	200 mbar	350 mbar	500 mbar	1 bar	2 bar
Ausgang Druckminderer	75 mbar	150 mbar	300 mbar	525 mbar	750 mbar	1,5 bar	3 bar
Maximum pressure	550 mbar	550 mbar	1 bar	1 bar	1 bar	2 bar	4 bar
Burst pressure	800 mbar	800 mbar	1,5 bar	1,5 bar	1,5 bar	3 bar	6 bar

Note: Older versions of the ADLM-PV can also come equipped with 500 mbar or 2 bar pressure sensors. In these cases, please refer to the gray-colored columns.

Note: Maximum distance to bubbling-through point: 50 m
 Level measuring possible in all liquids
 Aggressive and abrasive media are no problem
 During bubbling through period the output signal is held
 Bubbling through tube and tube or hose can be made of every possible material
 The end of the bubbling-through tube should have an angle of 45° (to have a defined point of bubbling)

Functional description

1. The system is in break time: A change of the level of liquid causes a proportional change of the pressure in the system and therefore also a change of the analog output signals.
2. Pulse time (valve open): The analog output signal holds the value it had when pulse time started. This value will not change during pulse time. The input pressure from the pressure reducer is switched via the opened valve to the pressure output for the bubbling-through unit. After a certain time and depending on tube / hose diameter and also the distance of the bubbling through point, air will escape at the end of the bubbling-through unit when the hydrostatic pressure is reached (density x filling height).
3. End of pulse time (valve is closed) = break time: After a certain time the pressure in the system is in balance (pressure at the bubbling through point = pressure at the pressure sensor). The analog output will now be released again. The pressure applied on the sensor will now cause a proportional signal again at the current / voltage output. A change of the liquid level will then cause a change of the system pressure and therefore also a change of the analog output signals.

● **Order Code**

E V X X X X X X - X X X

Input:	positive relative pressure	0																			
Output:	4...20 mA, 0...10 V		2																		
Supply:	24 VDC																				
Pressure sensor:	0...1000 mbar (standard)																			0	
	0...50 mbar																			1	
	0...100 mbar																			2	
	0...200 mbar																			3	
	0...350 mbar																			A	
Measuring range:	(please specify) ¹⁾																			0	
Interface:	RS232																				0
	RS232 and CANopen																				3
	RS232 and Profibus																				4
Casing:	AluCase 160x90x60																				0
	Plastics 162x92x60																				1
	Plastics 162x92x60 with EMC coating																				2
Configuration:	factory settings ²⁾																				0
	customized (please specify) ³⁾																				1
Special model:	No																				0
	Yes (please specify)																				1

- 1) Either a giving of pressure value (eg 0...600 mbar or 3 m water column) or the density of medium and the filling height (e. g. density 0,8 g/cm³ and filling height 4 m) is needed.
- 2) Factory settings: Measuring range: as given / analog output: 0...10 V and 4...20 mA / indication: 0...100,0% / linearization: without / pulse: 10 s / break: 3600 s / external tare: active (24 V).
- 3) Settings can be selected as per section *Technical Data*. If no values are given, factory settings will be used.